

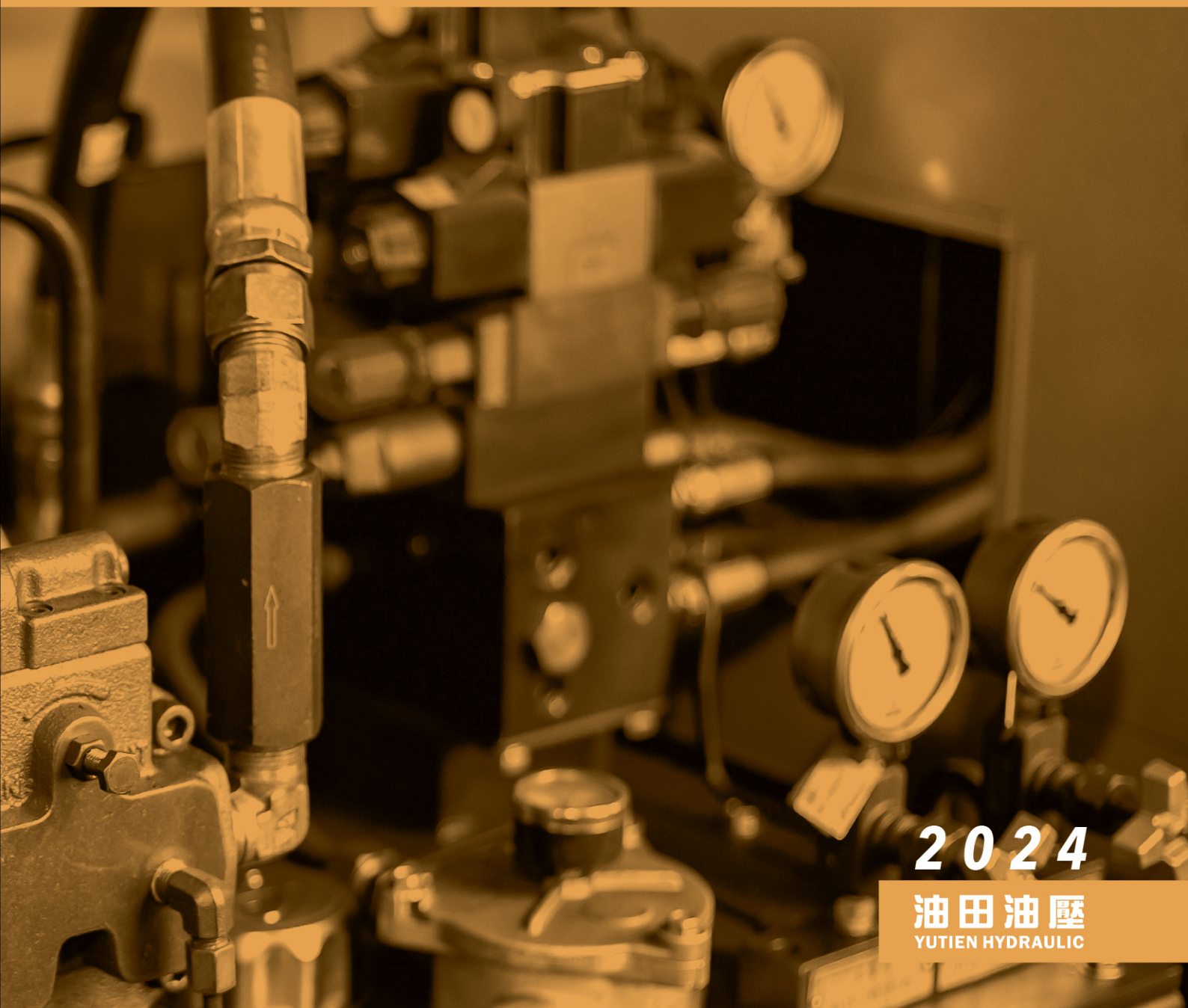

***SERVE WITH
POWER AND
HEART***



2024

油田油壓
YUTiEN HYDRAULIC



YUTiEN
HYDRAULIC

PHILOSOPHY

YUTIEN Company has many years of experience in the combined application of hydraulic components and hydraulic power, coupled with continuous investment in expertise and capital to improve production technology and quality. The product quality is now comparable to that of European, American, and Japanese products. And adhering to the continuous improvement of quality and service enthusiasm.

We not only provide customers with hydraulic parts requirements, but also provide customers with combination suggestions for different regional markets or different product applications. After passing the ISO 9001:2015 international quality certification, we look forward to serving customers with high standards of quality.

COMPANY PROFILE

YUTIEN HYDRAULIC was established in 1971, committed to the production of hydraulic parts and the design of automation systems and power combinations. In 1980, YUTIEN Company took the lead in developing the hydraulic power combination in Taiwan and cooperated with various machinery factories in the production of special projects.

The products and power combinations produced have been distributed all over the world. Although YUTIEN Company does not have the scale of a large enterprise, we have accumulated nearly 50 years of technical experience, and we can be regarded as the initiator and pioneer of hydraulic machinery in Taiwan.

HISTORY

1980

**Established related firm
"Shuo-Yuan Industry Co., Ltd."**

- Producing hydraulic components.
- The pioneer of those who developed power units in Taiwan.

And further started to provide customized services to meet each unique client.

1996

**Invested "THAI HYDRAULIC
TUBE CO., LTD." in Thailand.**

- THAI HYDRAULIC TUBE Company which runs hydraulic pipes, special machines and YUTIEN brand' s components and power units' business.

1971

**Established "New Wu-Jou
Hydraulic Machine Factory".**

Producing hydraulic components and designing hydraulic special purpose machines.

1982

- Company restructuring and changed a new name to "YUTIEN Hydraulic Industry Co., Ltd."

YUTIEN HYDRAULIC continues to engage in the manufacture of hydraulic components and power units, automotive system design, and further expands the import and export trade business of hydraulic components of multiple brands.

2006

- Passed ISO 9001:2000 certification. Offer much more systematic and efficient service.
 - Established the office and maintaining center "Pei-Guan Hydraulic Industry Co., Ltd.," in Xiamen.
- Provide express shipping and good after-sales service for the Chinese market.

2012

- The Taiwan head office and production plant relocated to a new facility in Wuri District, Taichung City.
- (The production area is about 6,500 square meters)

2003

- Established "Pei-Ying Hydraulic Industry Co., Ltd." in Foshan as our first China office.

2008

Established direct sales office in Shanghai, China.

2018

Passed the new version of international ISO 9001:2015 certification.

OUR CLIENTS

- The Aerospace Ind. Development Corp.
- NANYA Plastic Corp
- TAITA Chemical Company Ltd.
- FORMOSA Chemical & Fabric Corp.
- TAIWAN GLASS Ind. Corp.
- CHUNGHWA Telecom
- CHIH-LIEN Industrial Co., Ltd.
- TAH-CHUNG Steel Corp.
- TSAN KUN Trans-National Group.
- LEN-HWA Textile Co., Ltd.
- CAU-CHING-CHYUAN Co., Ltd.
- CHENG-LOONG Corp.
- Institute of Transportation. MOTC
- TAICHUNG Thermal Power Plants.
- TAIWAN-TAITUNG Irrigation Association
- TAIWAN NAN-TOU Irrigation Association.
- HSIUPING University of Science and Technology

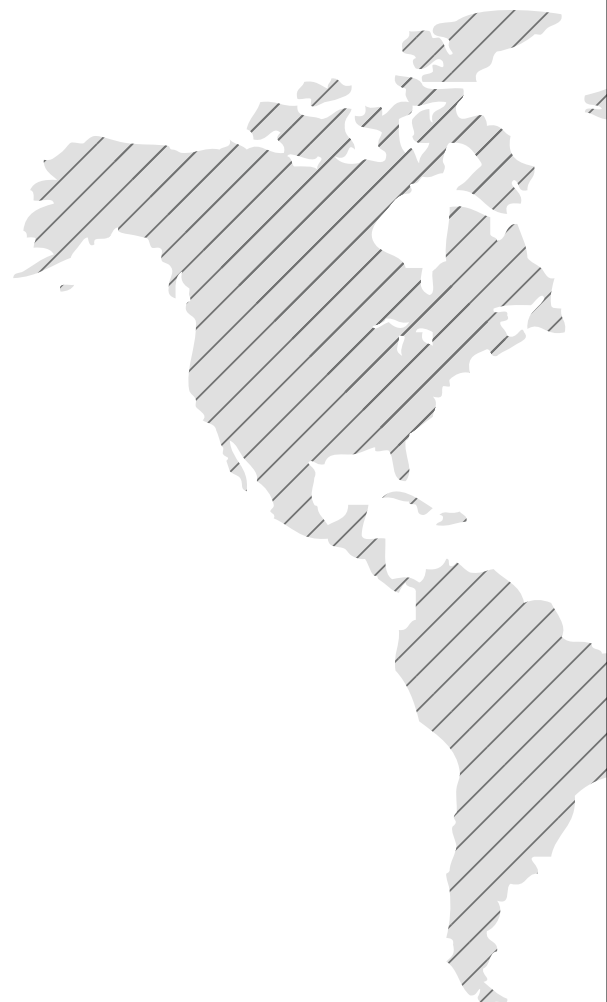

BRANCH

HEAD OFFICE/ FACTORY

- 📍 **YUTIEN HYDRAULIC INDUSTRY CO., LTD.**
No.2 Lane 129, Taiming North Road,
Wuri District, TAICHUNG CITY 414021, TAIWAN.
☎ +886-4-23356915
📠 +886-4-23356922

OVERSEAS DISTRIBUTION SERVICE

- 🔍 Please contact: overseas@yutien.com











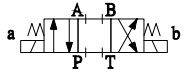

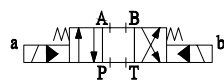

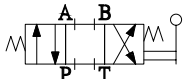

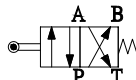

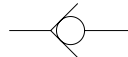

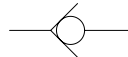

CHINA BRANCH

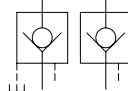
- 📍 **XIAMEN OFFICE**
PEI-GUAN HYDRAULIC INDUSTRY CO., LTD.
☎ +86-592-6383510
- 📍 **FOSHAN OFFICE**
PEI-YING HYDRAULIC INDUSTRY CO., LTD.
☎ +86-757-82127702
- 📍 **SHANGHAI OFFICE**
☎ 86-21-59740636

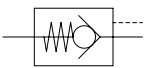

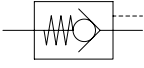
A

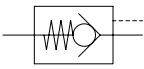
Directional Control Valves

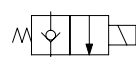
ITEM PICTURE	JIS GRAPHIC SYMBOL	PRODUCT NAME	PAGE
		Solenoid Operated Directional Control Valves	2
		Solenoid Controlled Pilot Operated Directional Control Valves	10
		Manually Operated Directional Control Valves	14
		Cam Operated Directional Control Valves	20
		In-Line Check Valves	24
		Right Angle Check Valves (ISO Sub-Plate)	26
		Right Angle Check Valves (Normal Type)	28
		Pilot Operated Check Valves	30
		PF Series Prefill Valves	36
		SG Series Prefill Valves	38
		PHP Series Prefill Valves	40
		Solenoid Operated Poppet Type Two-Way Valves	42

Solenoid Operated Directional Control Valves

JIS-Graphic Symbol

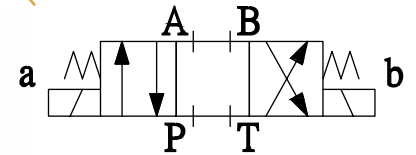

Feature

- The main body has double grooves for oil return to increase the passing flow and the operating pressure.
- New CNC precision machining, accurate size. With non-right-angle spool designed to reduce the cutting edge or sliding block issues caused by high pressure.
- Internal resistance is greatly increased.
- Internal back pressure is greatly increased.
- Oil-immersed type solenoid design with stable action and low noise.
- One-piece coil, with good water-proof effect, good heat dissipation and high temperature resistance.
- 3-positions/4-ways or 2-positions/4-ways spool type directional control valve operated by 5-hole solenoid. Suitable for block or base plate installation.
- Solenoid valve installation dimensions are in line with international standards.
- With neon light to indicate the direction of action.
- DIN Type plug-in and Terminal Box type connection, with direction indicator light on both sides.

Model Description

DSW	-02	-3C60	R	-D	-A110
Model /Series	Thread Code Size (Inch)	Spool Actuated/ Function	Assembly Type	Connection type	Coil Type
Solenoid Operated Directional Control Valves	02 : 1/4" 03 : 3/8"	Please refer to the spool function table (p. A4~A5)	None: Standard R: Reverse	B: Terminal Box Type D: Plug-In Type (DIN)	AC : A110 AC : A220 DC : DC12 DC : DC24 RF : R110 RF : R220

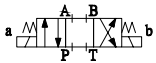

Specification

Model /Type	Rated Flow (Max.) L/min	Operating Pressure (Max.) Kgf/cm ²	Back Pressure (Max.) Kgf/cm ²	Conversion Frequency Times/min
DSW-02	60	215	70~160	240
DSW-03	100			

DSW-02

Voltage/Current Type	AC				DC		RF	
Operating Voltage (V)	110		220		12	24	110	220
AC Frequency (Hz)	50	60	50	60				
Holding Current (A)	0.43	0.43	0.22	0.22	1.72	1.05	0.38	0.19
Inrush Current (A)	1.45	1.45	0.89	1.01				
IP Ratings	IP65							
Coil/Wire Level	PEWH							
Coil Temperature Resistance	180°C							

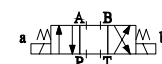

DSW-03

Voltage/Current Type	AC				DC		RF	
Rated Voltage (V)	110		220		12	24	110	220
AC Frequency (Hz)	50	60	50	60				
Holding Current (A)	0.62	0.69	0.27	0.33	2.03	1.48	0.54	0.27
Inrush Current (A)	3.41	4.14	1.58	1.95				
IP Ratings	IP65							
Coil/Wire Level	PEWH							
Coil Temperature Resistance	180°C							

Directional Control Valves
 Solenoid Operated Directional Control Valves

Spool Function Table

Dual-Coil 3-Positions			
Spring Return Centered			
Spool Code	Standard	Spool Code	Standard
3C2		3C7	
3C3		3C8	
3C4		3C9	
3C40		3C10	
3C5		3C11	
3C6		3C12	
3C60			

Spool Code	Standard	Reverse
------------	----------	---------

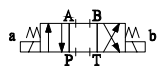
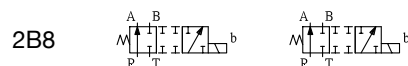
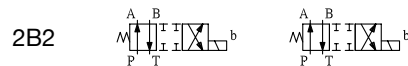

Directional Control Valves
 Solenoid Operated Directional Control Valves

Single-Coil 2-Positions			
Spring Offset			
	Spool Code	Standard	Reverse
	2B2A		
	2B3A		
	2B4A		
	2B40A		
	2B5A		
	2B6A		
	2B60A		
	2B7A		
	2B8A		
	2B9A		
	2B10A		
	2B11A		
	2B12A		

Single-Coil 2-Positions		
Spring Offset		
Spool Code	Standard	Reverse
2B2B		
2B3B		
2B4B		
2B40B		
2B5B		
2B6B		
2B60B		
2B7B		
2B8B		
2B9B		
2B10B		
2B11B		
2B12B		

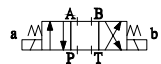

Directional Control Valves
 Solenoid Operated Directional Control Valves

Dimensions

DSW-02-※-B-A※
ISO 4401-AB-03-4-A

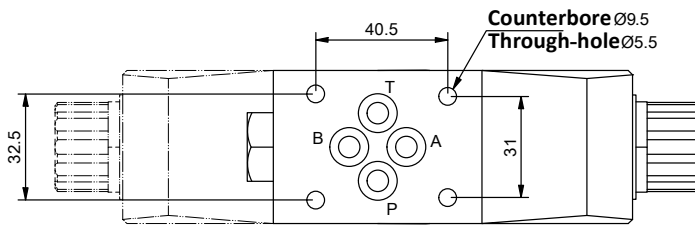
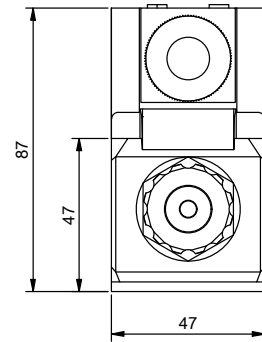
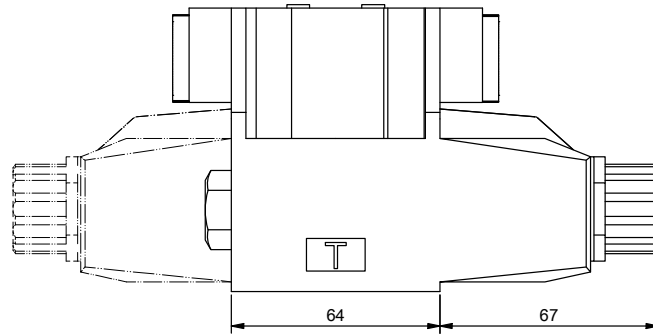

DSW-02-※-B-DC※
ISO 4401-AB-03-4-A

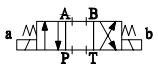
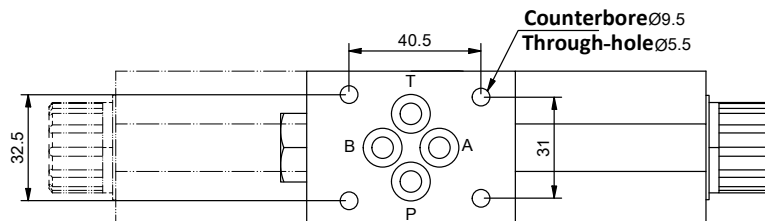
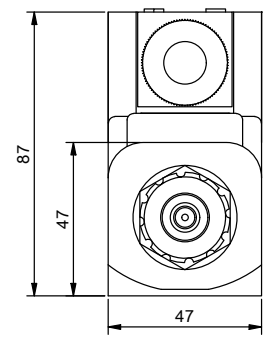
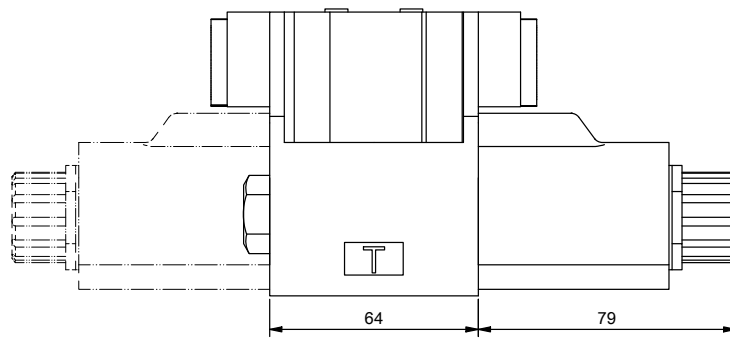

Directional Control Valves
Solenoid Operated Directional Control Valves

Dimensions

DSW-02-※-D-A※
ISO 4401-AB-03-4-A

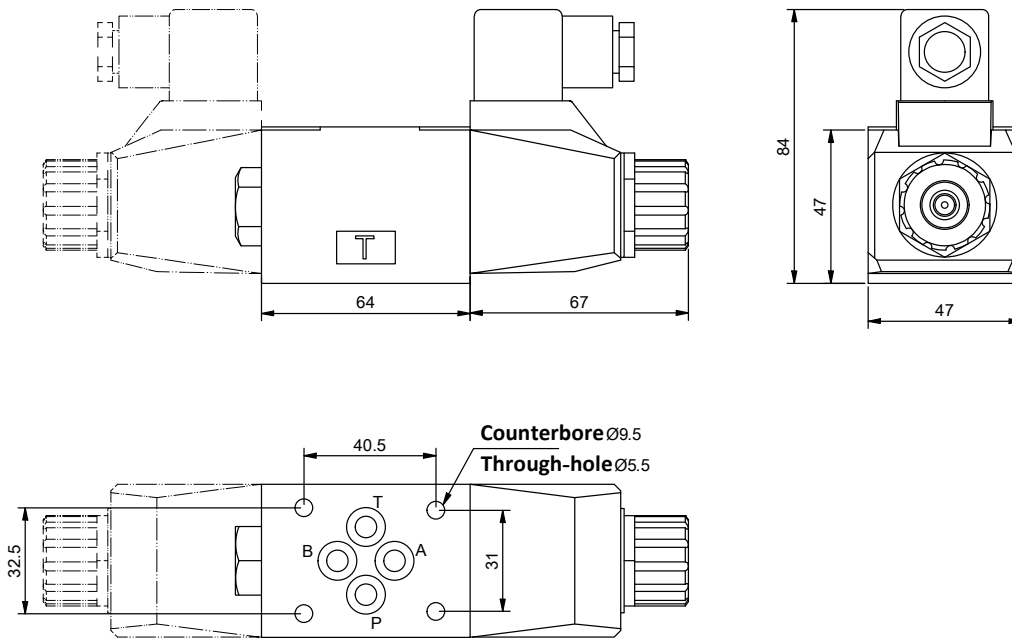

DSW-02-※-D-DC※
ISO 4401-AB-03-4-A

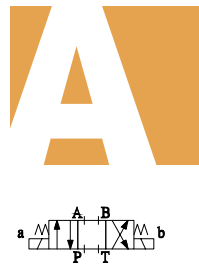
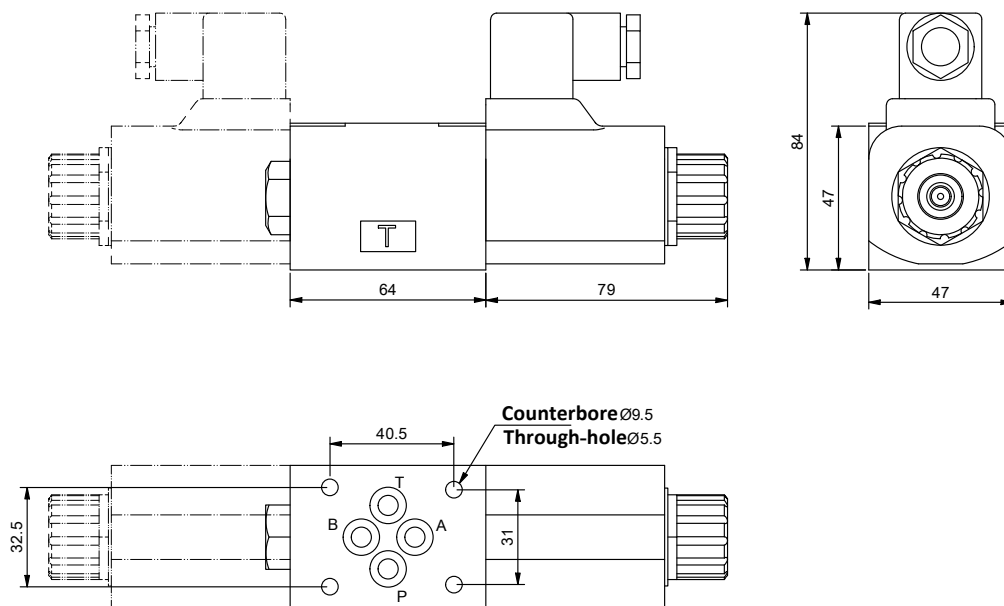

Directional Control Valves
Solenoid Operated Directional Control Valves

Dimensions

DSW-03-~~*~~B-A~~*~~
ISO 4401-AC-05-4-A

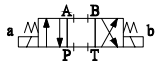
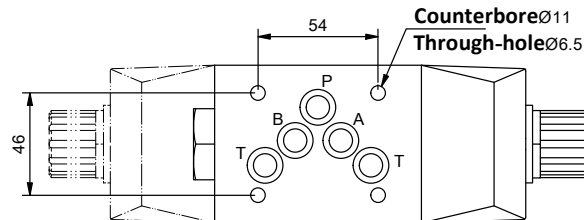
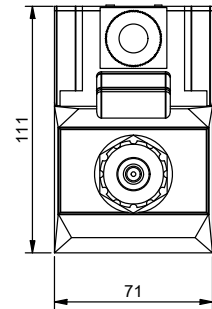
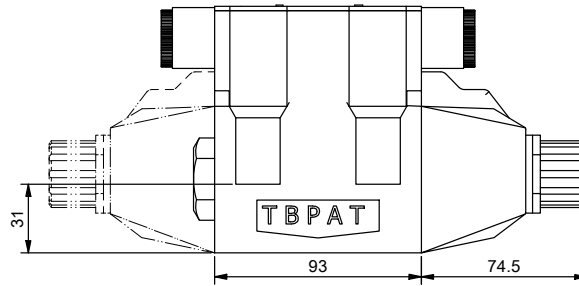

DSW-03-~~*~~B-DC~~*~~
ISO 4401-AC-05-4-A

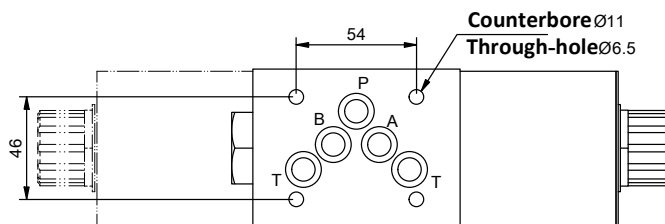
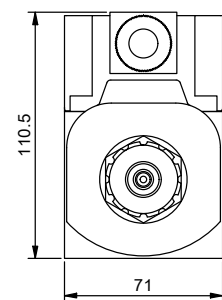
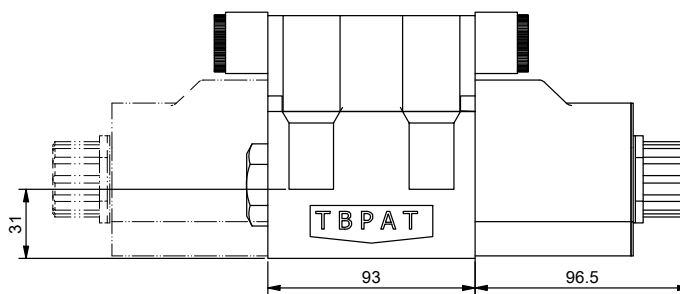

Directional Control Valves
 Solenoid Operated Directional Control Valves

Dimensions

DSW-03-※-D-A※
ISO 4401-AC-05-4-A

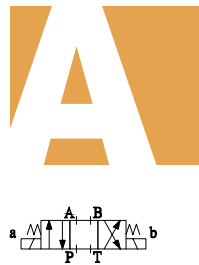
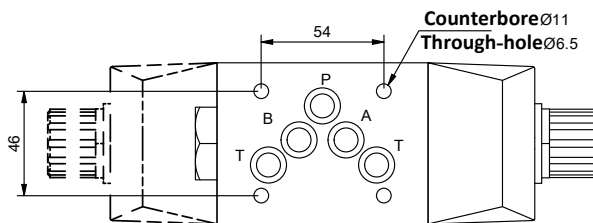
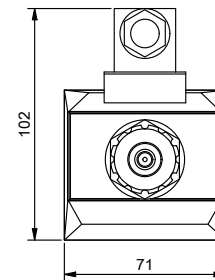
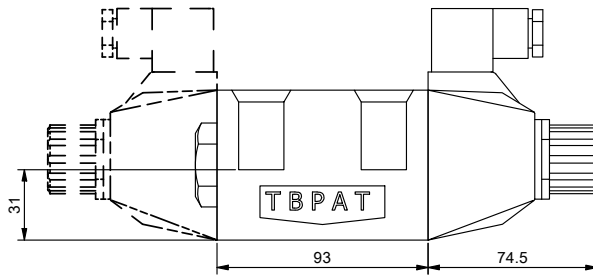

DSW-03-※-D-DC※
ISO 4401-AC-05-4-A

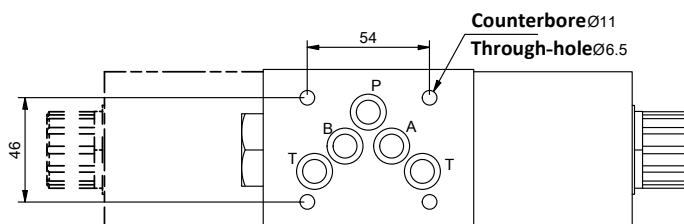
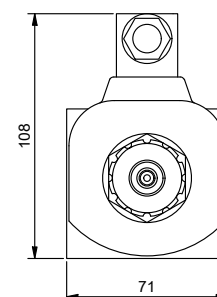
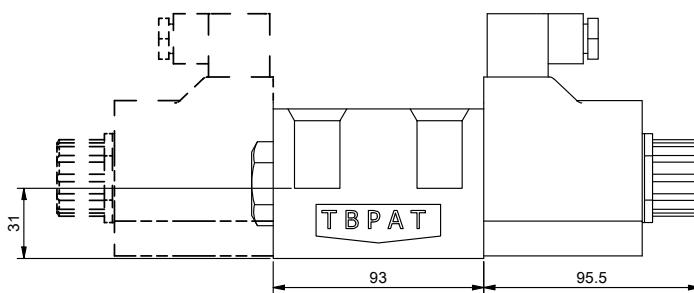

Directional Control Valves
Solenoid Operated Directional Control Valves

Solenoid Controlled Pilot Operated Directional Control Valves



JIS-Graphic Symbol

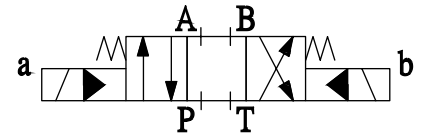

Feature

- Generally used in combination with the Solenoid Operated Directional Valve and the Pilot Operated Directional Valve.
- Both the Pilot method and the oil drain method can be freely changed.

Model Description

DP	-04	S	-3	C
Model /Series	Thread Code Size (Inch)	Stroke Adjustment	Valve Positions	Spool Actuated

DP: Solenoid Controlled Pilot Operated Directional Valves	03 : 3/8" 04 : 1/2" 06 : 3/4"	None: Not Required S: Stroke Adjustment	2: Two Positions 3: Three Positions	B: Spring Offset C: Spring Return Centered N: Without Spring
DPH: Large-Flow Solenoid Controlled Pilot Operated Directional Valves	10 : 1-1/4" 16 : 2" (Customizable size)			

2	-II	-B	-DC24V
Spool Function	Pilot / Drain Types	Connection Type (Solenoid Valve) (Optional)	Coil Type (Solenoid Valve) (Optional)

Please refer to the spool function table (p. A11)

II: Internal Pilot-Internal drain	None: Not Required	None: No Coil
IE: Internal Pilot-External drain	B: Terminal Box Type	AC: AC110 /AC220
EI: External Pilot-Internal drain	D: Plug-In Type (DIN)	DC: DC12V/DC24V
EE: External Pilot-External drain		RF: RF110 /RF220

Specification

Model /Type	Rated Flow (Max.) L/min	Operating Pressure (Max.) Kgf/cm ²	Back Pressure (Max.) Kgf/cm ²	Conversion Frequency (Max.) Times/min
DP-03	100	250	140	120
DP-04	150			
DPH-04	200			
DP-06	300			
DP-10	500			

Spool Function Table

3-Positions	2-Positions	
Spring Return Centered	Dual-Coil Without Spring	Single-Coil Spring Offset

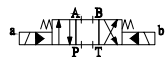
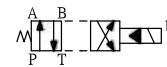
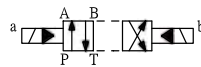
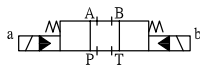

Spool Code	Standard	Spool Code	Standard
2		2	
3		3	
4			
6			
60			
10			
12			

Directional Control Valves
Solenoid Controlled Pilot Operated
Directional Valves

Dimensions

DP-04

ISO 4401-AD-07-4-A

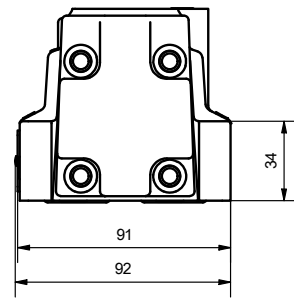
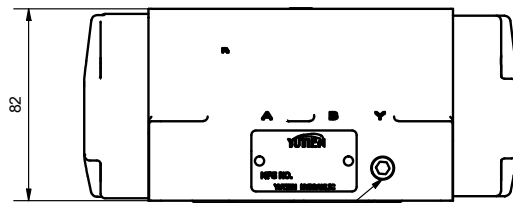
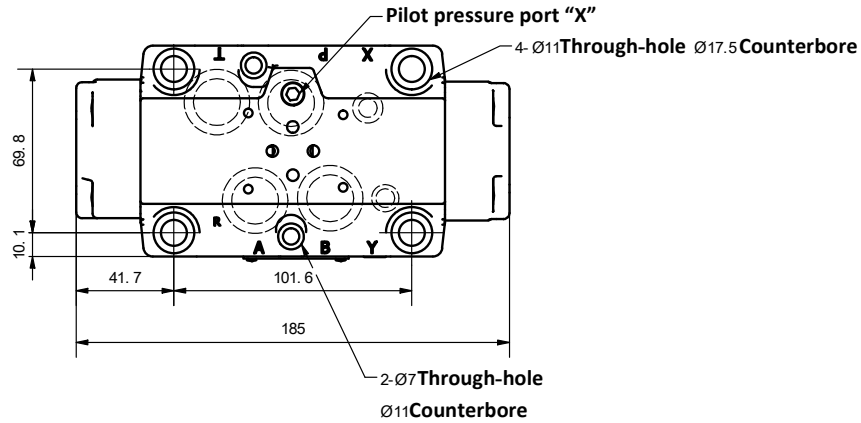

Pilot Drain port "Y"

DPH-04

ISO 4401-AD-07-4-A

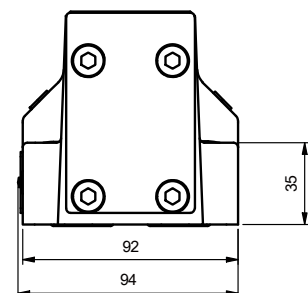
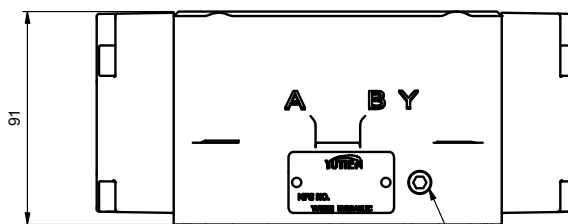
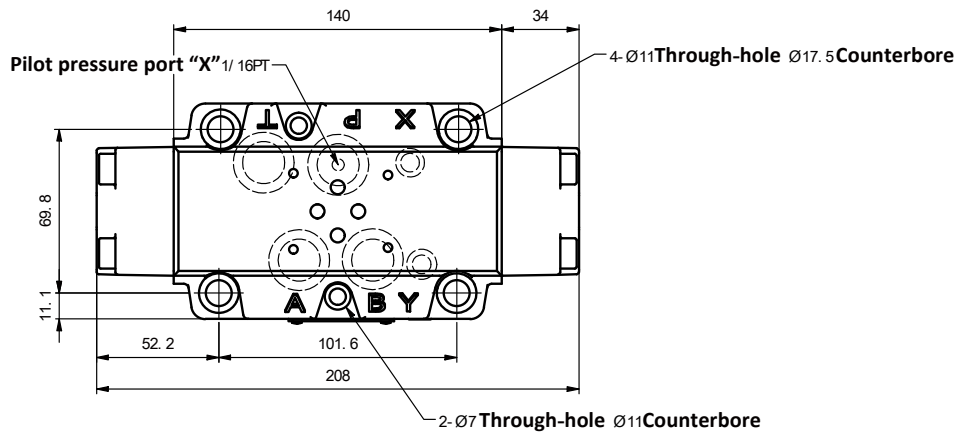

Pilot Drain port "Y"

Directional Control Valves
Solenoid Controlled Pilot Operated
Directional Valves

Dimensions

DP-06

ISO 4401-AE-08-4-A

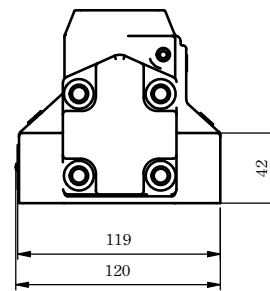
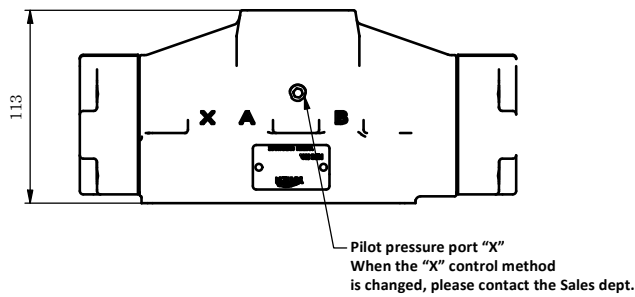
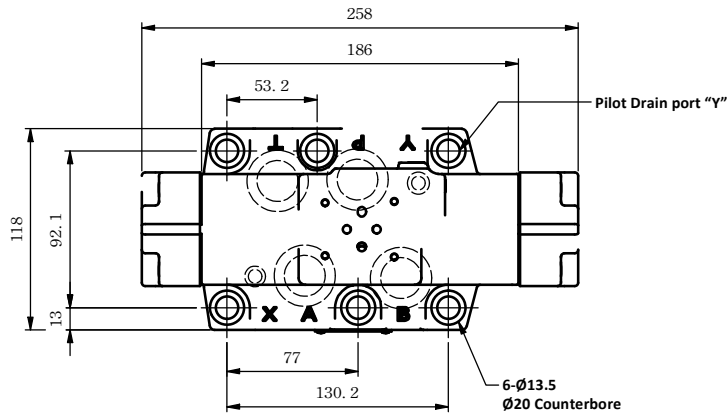

DP-10

ISO 4401-AF-10-4-A

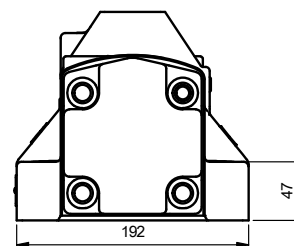
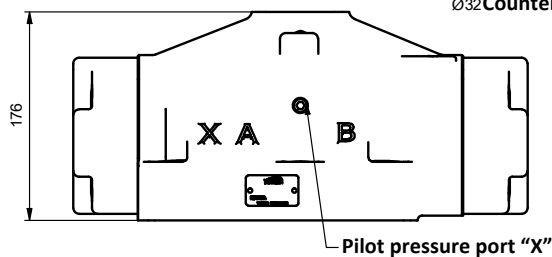
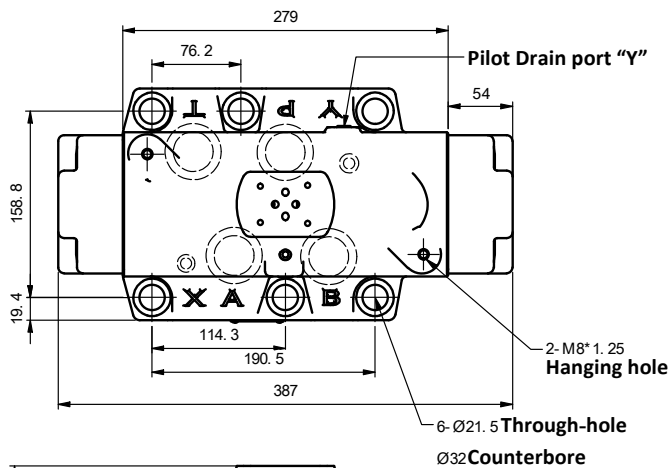

When the "X" control method is changed, please contact the Sales dept.

Directional Control Valves
Solenoid Controlled Pilot Operated
Directional Valves

Manually Operated Directional Control Valves



JIS-Graphic Symbol

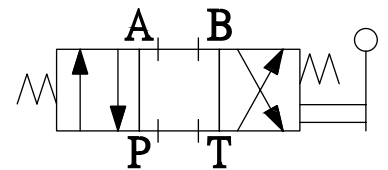
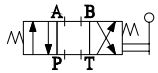

Feature

- Manually Operated control the spool position to change the direction of oil flow.

Model Description

D	M	T	-02
Model /Series	Operating Method	Installation Type	Thread Code Size (Inch)

Manually Operated Directional Control Valves

M: Vertical Type
R: Rotary Type

T: Threaded Connection
G: Sub-Plate Mounting

02 : 1/4"
03 : 3/8"
04 : 1/2"
06 : 3/4"
10 : 1-1/4"
(Customizable size)

-3	C	2
Valve Positions	Spool Operating	Spool Function

2: Two Positions
3: Three Positions

B: Spring Offset
C: Spring Return Centered
D: Detent Type (Without spring)

Please refer to the spool function table (p. A16)

Specification

Model Type		Rated Flow (Max.) L/min	Operating Pressure (Max.)Kgf/cm ²	Back Pressure (Max.) Kgf/cm ²	Weight kg	
Vertical Handle Type	Sub-Plate Mounting	DMG-02	50	70	20	1.5
		DMG-03	50	250	100	3.6
	Threaded Connection	DMT-03	50	250	100	4.5
		DMT-04	100	250	140	7.1
		DMT-06	180	205	140	10.8
		DMT-10	300	205	140	22.7
Rotary Handle Type	DRT-03	50	70	20	3.7	

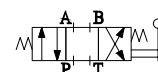

Directional Control Valves
Manually Operated Directional Control Valves

Spool Function Table

3-Positions		2-Positions	
C: Spring Return Centered	D: Detent Type (Without spring)	B: Spring Offset	D: Detent Type (Without spring)

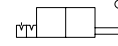
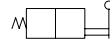
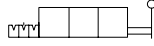
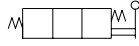

Spool Code	JIS-Graphic Symbols	Spool Code	JIS-Graphic Symbols
------------	---------------------	------------	---------------------

2

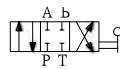

2



3



3



4



6

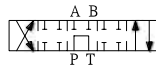

60

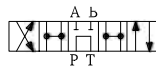

10



12

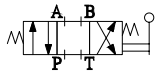

Directional Control Valves
 Manually Operated Directional Control Valves

Dimensions

DMG-02

ISO 4401-AB-03-4-A

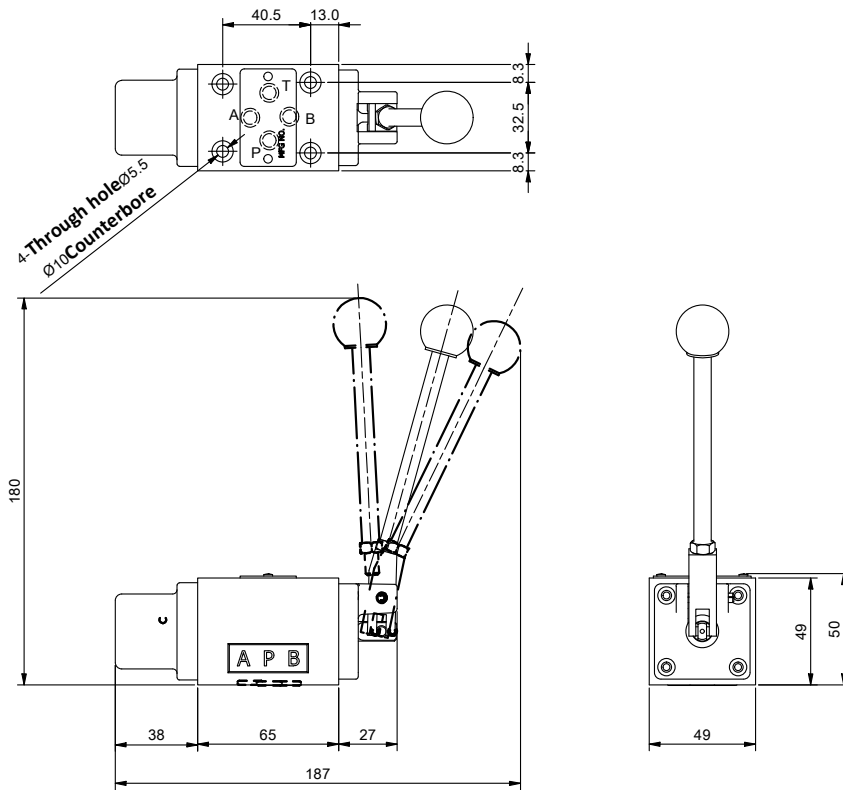

DMG-03

ISO 4401-AC-05-4-A

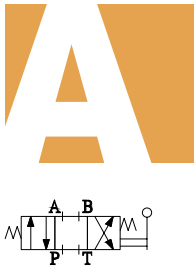
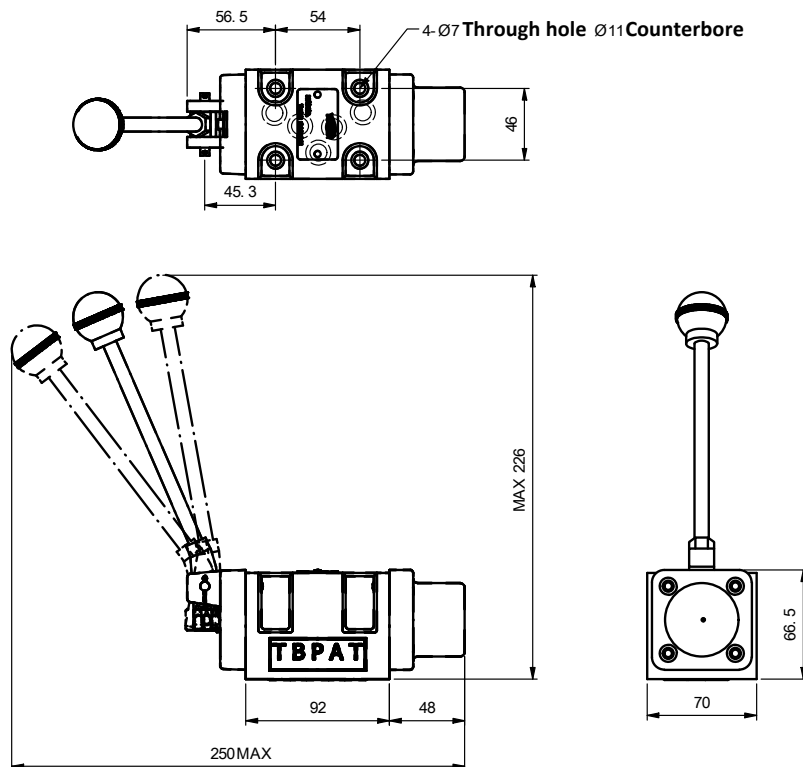

Directional Control Valves
Manually Operated Directional Control Valves

Dimensions

DMT-03/04/06/10

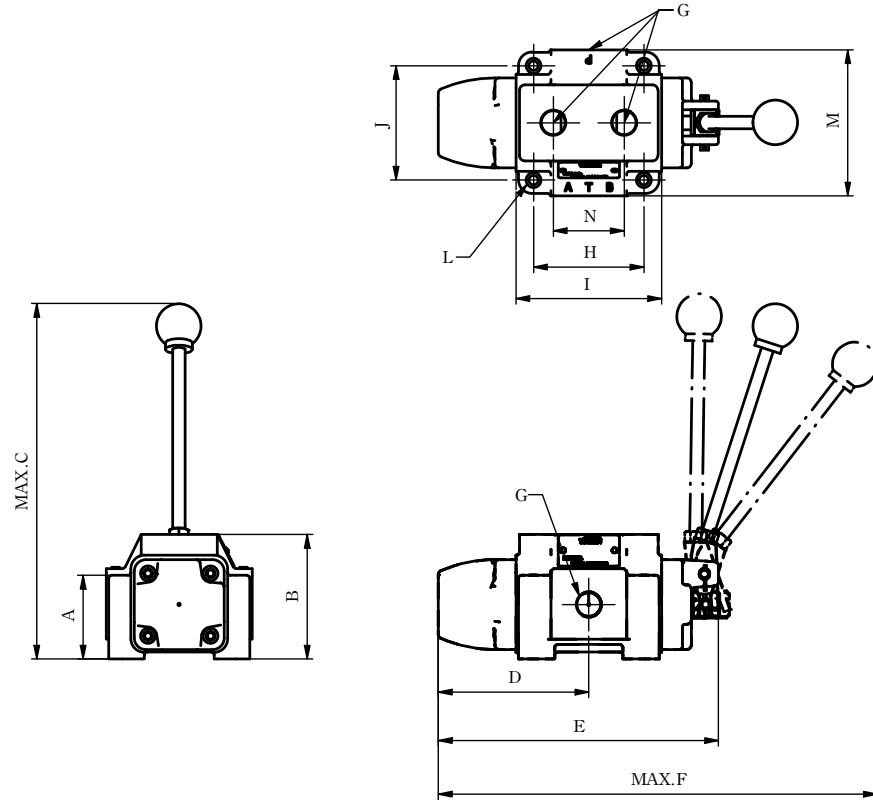

Model	A	B	C	D	E	F	G
DMT-03	74	83	268	94	177	292	4-Rc 3/8
DMT-04	65	90	260	110.5	206.3	314.1	4-Rc 1/2
DMT-06	70	97.5	305	135.5	258.8	419	4-Rc 3/4
DMT-10	94	120	385	178	330	528.8	4-Rc 1 1/4

Model	H	I	J	L	M	N
DMT-03	53	92	48	Ø11 deep, Ø7 through	76	40
DMT-04	81	107	84	Ø11 deep, Ø7 through	110	52
DMT-06	100	130	95	Ø17.5 deep, Ø11 through	128	66
DMT-10	133	171	126	Ø19 deep, Ø13 through	164	84

Directional Control Valves
 Manually Operated Directional Control Valves

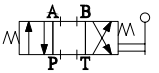

Directional Control Valves
Manually Operated Directional Control Valves

Cam Operated Directional Control Valves



Feature

- Simple cam design controls the spool position to change the direction of oil flow.

Model Description

DC	G	-02	NC
Model /Series	Installation Type	Thread Code Size (Inch)	Spool Type

Cam Operated Directional Control Valves

G: Sub-Plate Mounting
T: Threaded Connection

02 : 1/4

NO: Normally Open
NC: Normally Closed

JIS-Graphic Symbol

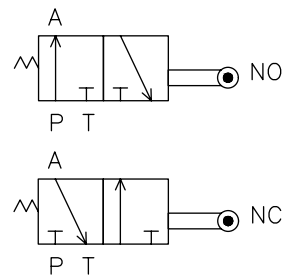

Model /Type	Rated Flow (Max.)L/min	Operating Pressure (Max.) Kgf/cm ²	Back Pressure (Max.) Kgf/cm ²	Weight kg
Sub-Plate Mounting DCG-02	45	250	70	1.5
Threaded Connection DCT-02				1.4

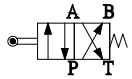

Dimensions

DCG-02

ISO 4401-AB-03-4-A

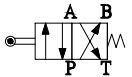
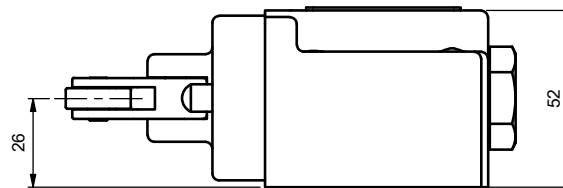
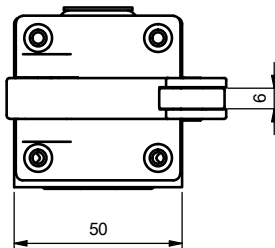
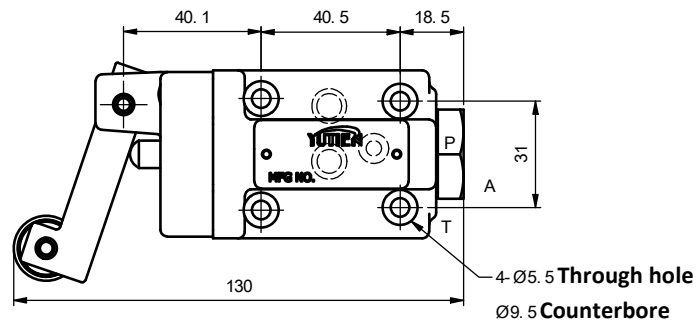
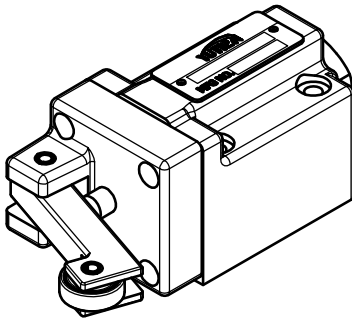

Directional Control Valves
Cam Operated Directional Control Valves

Dimensions

DCT-02

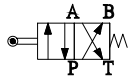
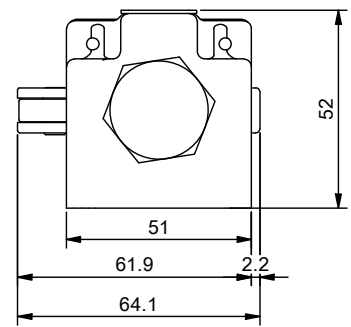
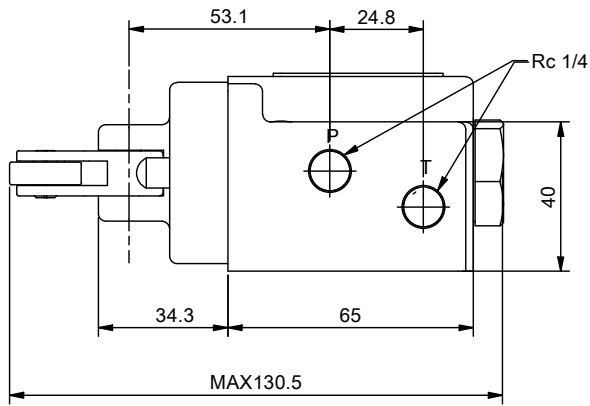
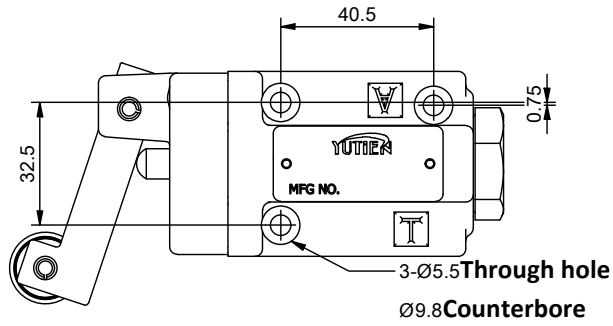
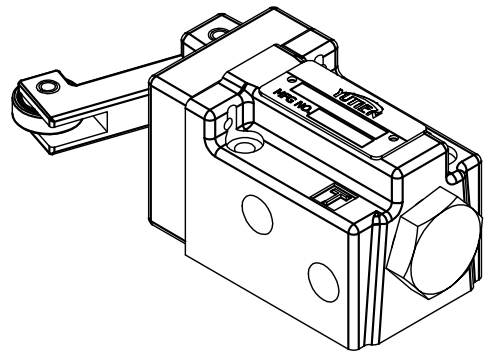
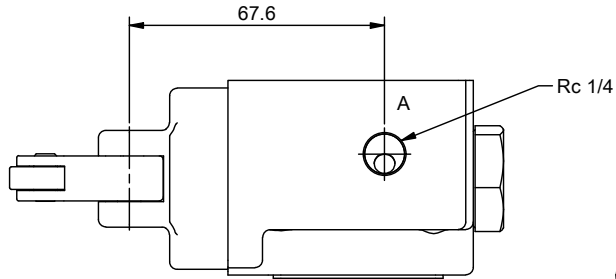

Directional Control Valves
Cam Operated Directional Control Valves

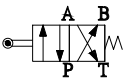

Directional Control Valves
Cam Operated Directional Control Valves

In-Line Check Valves



JIS-Graphic Symbol

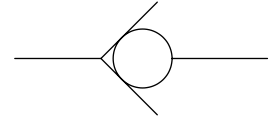

Feature

- When the pressure reaches the cracking pressure, the oil flow will freely, and completely prevent reverse flow.
- Can be used as a safety device for cooler and return oil filters.
- Gravity-type check valve can be used as an external pressure relief for other control valves and maintain the valves with normal operation.

Model Description

CVT	-03	-50
Model /Series	Thread Code Size (Inch)	Cracking Pressure Kg/cm ²
In-Line Check Valves	03 : 3/8"	05 : 0.5 50 : 5
	04 : 1/2"	
	06 : 3/4"	
	08 : 1"	
	10 : 1-1/4"	
	12 : 1 1/2"	
	16 : 2"	

Specification

Model /Type	Rated Flow (Max.) L/min	Operating Pressure (Max.) Kg/cm ²	Cracking Pressure (Max.) Kg/cm ²	Weight kg
CVT-03	40	210	0.5 5	0.19
CVT-04	60			0.32
CVT-06	100			0.50
CVT-08	150			1.12
CVT-10	200			2.10
CVT-12	280			2.20
CVT-16	400			3.96

Dimensions

CVT-02/03/04/06/08

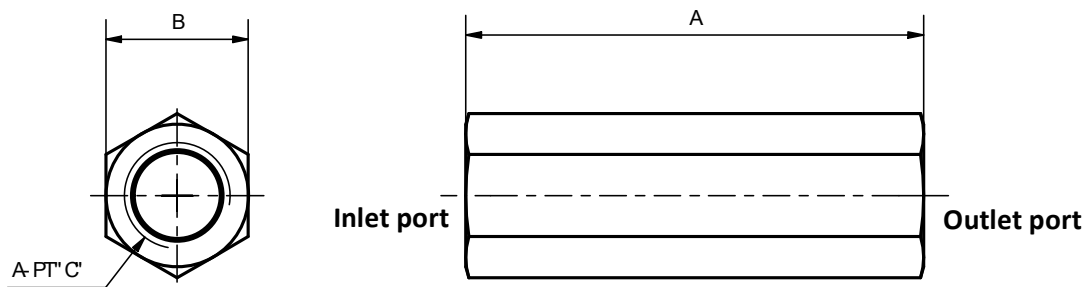

CVT-10/12/16

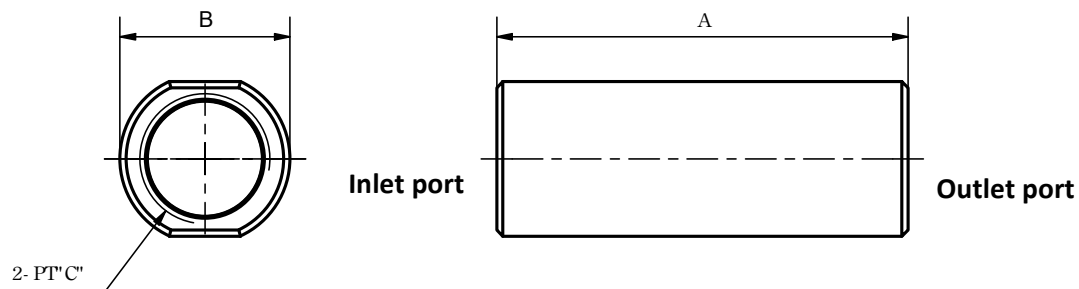

Model	A	B	C
CVT-03	74	23	3/8"
CVT-04	80	29	1/2"
CVT-06	90	35	3/4"
CVT-08	113	46	1"
CVT-10	133	55	1 1/4"
CVT-12	139	60	1 1/2"
CVT-16	154	75	2"

Directional Control Valves
In-Line Check Valves

Right Angle Check Valves (ISO Sub-Plate)



JIS-Graphic Symbol

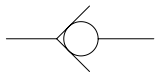
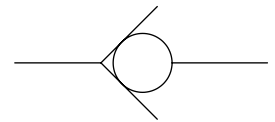

Feature

- When the pressure reaches the cracking pressure, the oil flow will freely, and completely prevent reverse flow.
- Can be used as a safety device for cooler and return oil filters.
- Gravity-type check valve can be used as an external pressure relief for other control valves and maintain the valves with normal operation.

Model Description

CRNG	-03	-S	-50
Model /Series	Thread Code Size (Inch)	Stroke Adjustment	Cracking Pressure Kg/cm ²
Right Angle Check Valves (ISO Sub-Plate)	03 : 3/8" 06 : 3/4" 10 : 1-1/4"	None: Not Required S: Stroke Adjustment	05 : 0.5 50 : 5

Specification

Model /Type	Rated Flow (Max.) L/min	Operating Pressure (Max.) kgf/cm ³	Cracking Pressure kgf/cm ³	Weight kg
CRNG-03	40	250	0.5 5	1.9
CRNG-06	125			3.3
CRNG-10	250			5.7

Dimensions

CRNG-03/06

CRNG-03 : ISO 5781-AG-06-2-A
CRNG-06 : ISO 5781-AH-09-2-A

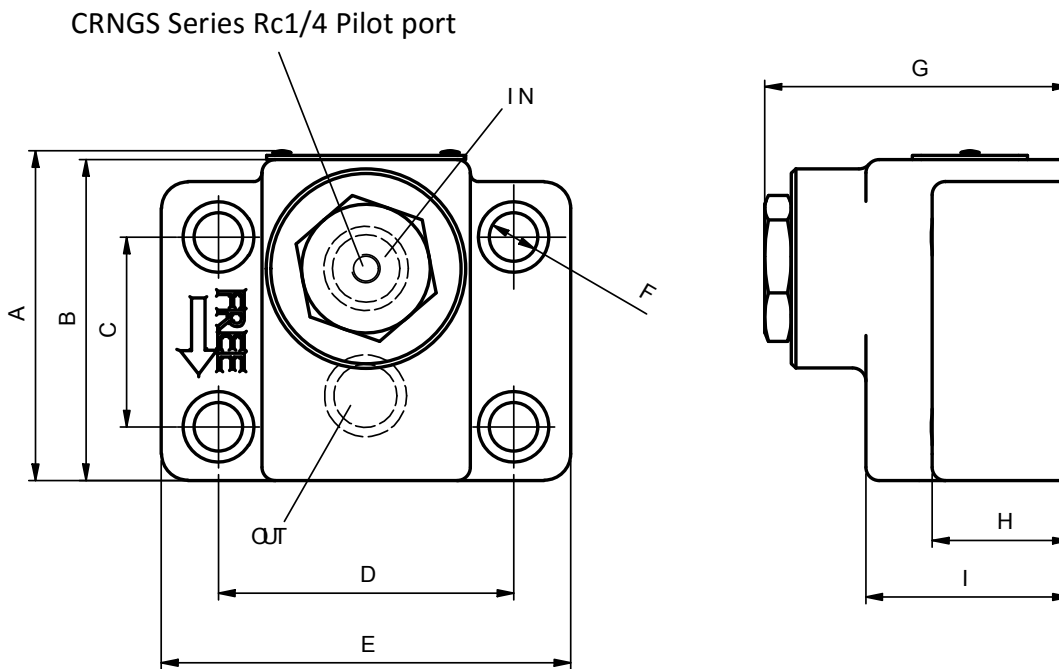

Model	A	B	C	D	E	F	G	H	I
CRNG(S)-03	74	72	42.9	66.7	92	4-Ø11	68.5	31	45.5
CRNG(S)-06	96	94	60.3	79.4	102	4-Ø11	85.5	38	51



CRNG-10

CRNG-10 : ISO 5781-AJ-10-2-A

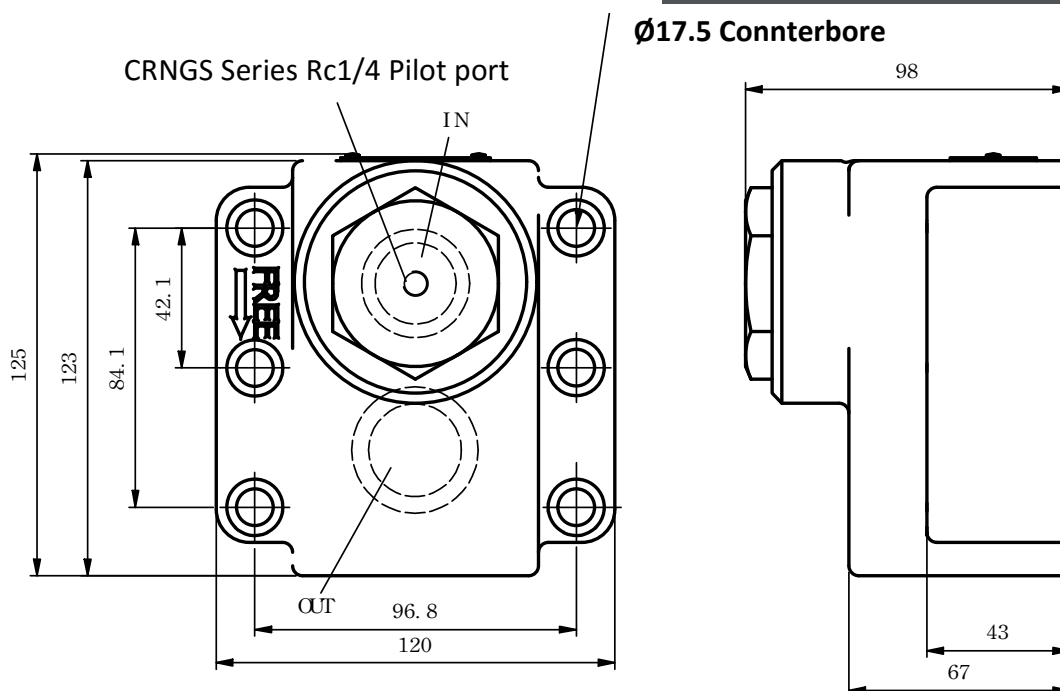

Directional Control Valves
Right Angle Check Valves (ISO Sub-Plate)

Right Angle Check Valves (Normal Type)



JIS-Graphic Symbol

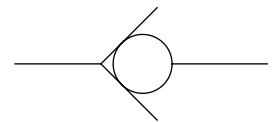

Feature

- When the pressure reaches the cracking pressure, the oil flow will freely, and completely prevent reverse flow.
- Can be used as a safety device for cooler and return oil filters.
- Gravity-type check valve can be used as an external pressure relief for other control valves and maintain the valves with normal operation.

Model Description

CRG	-03	-S	-50
Model /Series	Thread Code Size (Inch)	Stroke Adjustment	Cracking Pressure Kg/cm ²
Right Angle Check Valves (Normal Type)	03 : 3/8" 06 : 3/4" 10 : 1-1/4"	None: Not Required S: Stroke Adjustment	05 : 0.5 50 : 5

Specification

Model	Rated Flow (Max.) L/min	Operating Pressure (Max.) kgf/cm ²	Cracking Pressure Kg/cm ²	Weight kg
CRG-03	40	250	0.5 5	1.5
CRG-06	125			3.8
CRG-10	250			7.0

Dimensions

CRG-03/06/10

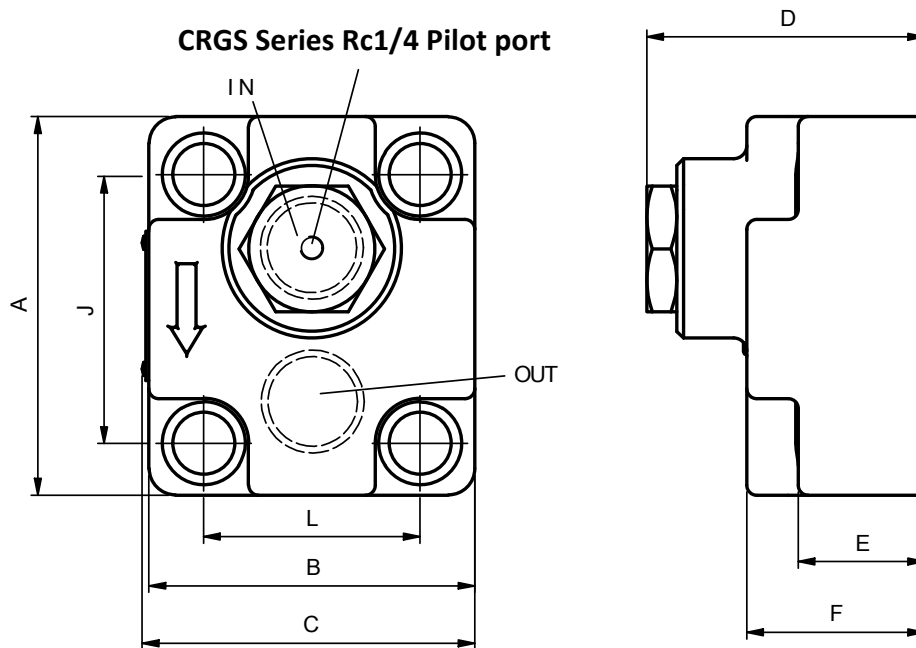

Model	A	B	C	D	E	F	J	L
CRG(S)-03	82	70	72	69	36	46	60.3	47.6
CRG(S)-06	115	98	100	85	39	56	80.9	65.1
CRG(S)-10	130	130	132	97.5	48.5	65.4	92.1	92.1



Directional Control Valves
Right Angle Check Valves (Normal Type)

Pilot Operated Check Valves



JIS-Graphic Symbol

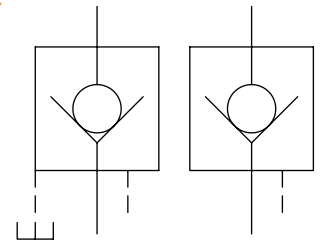

Feature

- The pilot check valve only allows the oil to flow in one-way direction when the cracking pressure is reached, and completely prevent reverse flow.

Model 説明

PV	G	-03	-50	E
Model /Series	Installation Type	Thread Code Size (Inch)	Cracking Pressure Kg/cm ²	Pilot / Drain Types
Pilot Operated Check Valves	TI: In-Line Threaded T: Threaded Connection G: Sub-Plate Mounting TF: Flange Connection	03 : 3/8" 04 : 1/2" 06 : 3/4" 10 : 1-1/4" 16 : 2"	02 : 0.2 05 : 0.5 50 : 5	I: Internal drain E: External drain

Specification

Model	Rated Flow (Max.) L/min	Operating Pressure (Max.) Kg/cm ³	Cracking Pressure Kg/cm ²	Weight kg	
Sub-Plate Mounting	PVG-03	50	25	0.5 5	4.0
	PVG-04	75			4.0
	PVG-06	125			7.5
	PVG-10	320			12.3
Threaded Connection	PVT-03	50	25	0.5 5	4.0
	PVT-04	75			4.0
	PVT-06	125			6.4
	PVT-10	320			12.1

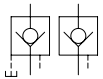

(Internal / External) Drain Connection Types

Internal drain (Fig. A): Reverse flow, when the outlet port P1 directly returns to tank, the Internal drain is usually used.

External drain (Fig. B): Reverse flow, when back pressure is applied at P1 outlet port, the external drain must be used.

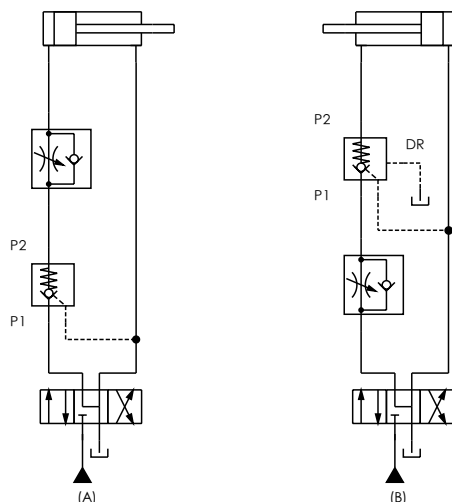

Dimensions

PVG-03/06

PVG-03 : ISO 5781-AG-06-2-A
PVG-06 : ISO 5781-AH-08-2-A

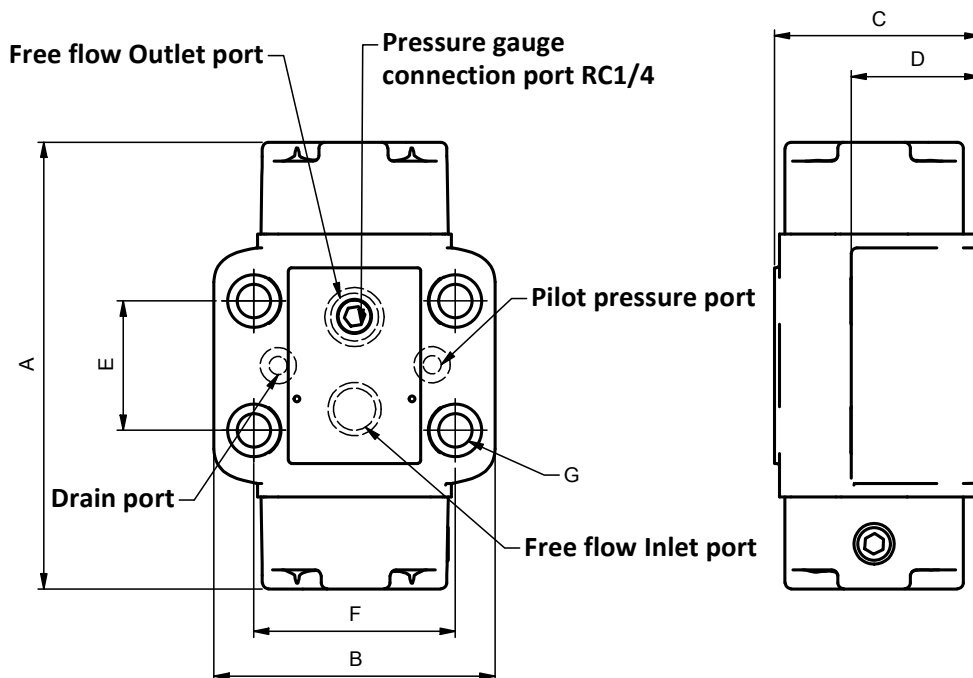
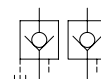

Model	A	B	C	D	E	F	G
PVG-03	152	92	68	42.5	42.9	66.7	4-Ø11
PVG-06	175	103	83	73	60.3	79.4	4-Ø11

Directional Control Valves
 Pilot Operated Check Valves

Dimensions

PVG-10

PVG-10 : ISO 5781-AJ-10-2-A

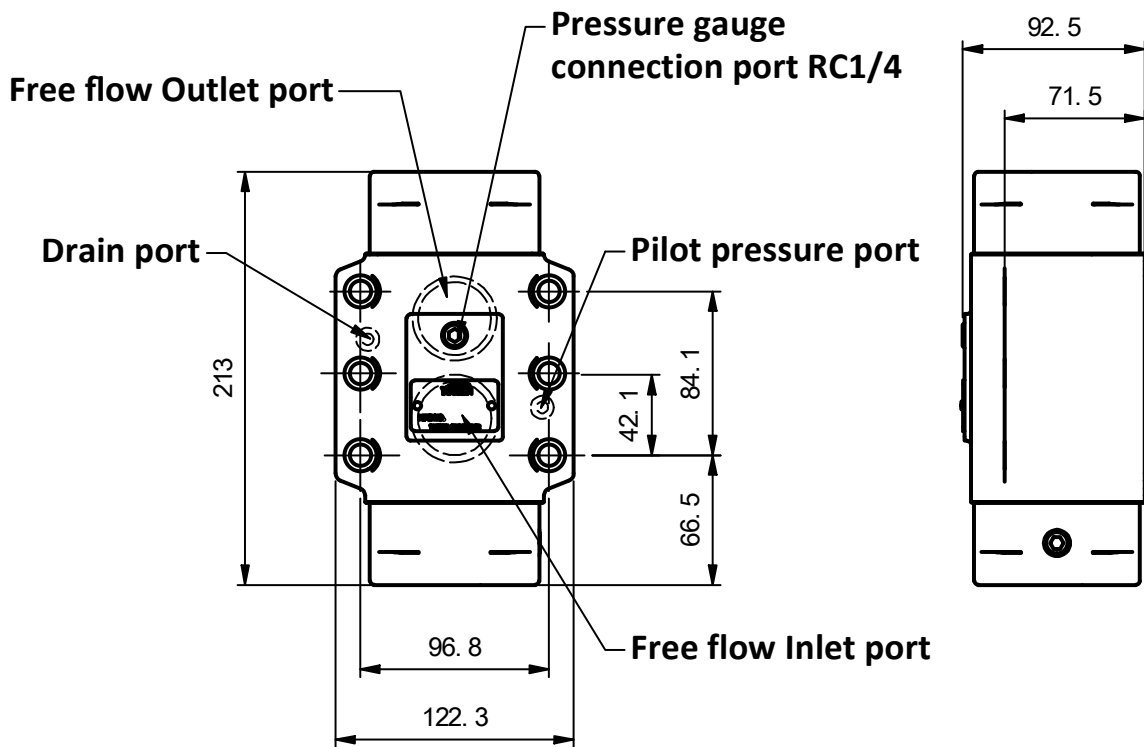

Directional Control Valves
Pilot Operated Check Valves

Dimensions

PVT-03/04/06

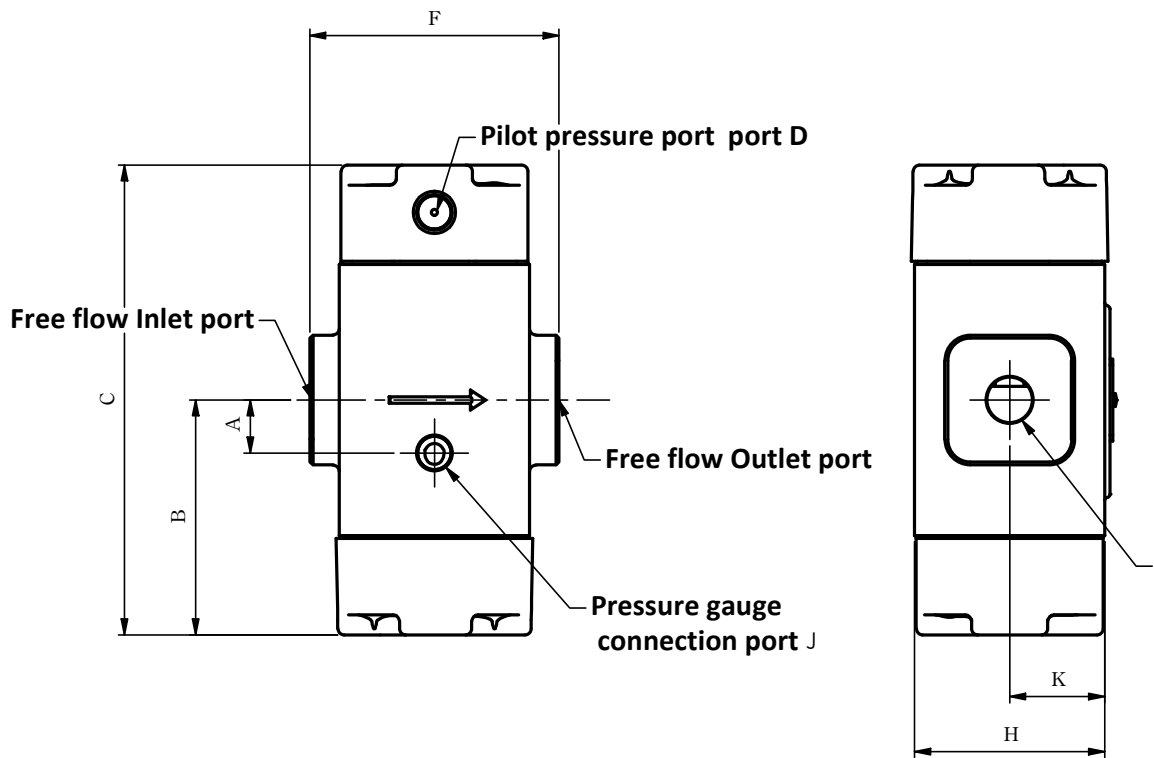

Model	A	B	C	D	E	F
PVT-03 04	16.5	76	171.5	RC 1/4	44.5	89
PVT-06	21.5	87	174	RC 1/4	48.5	97.6

Model	G	H	I	J	K
PVT-03 04	60	65	RC 3/4	RC 1/4	32.5
PVT-06	70.5	81.5	RC 3/4	RC 1/4	41

Directional Control Valves
Pilot Operated Check Valves

Dimensions

PVT-10

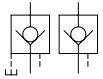
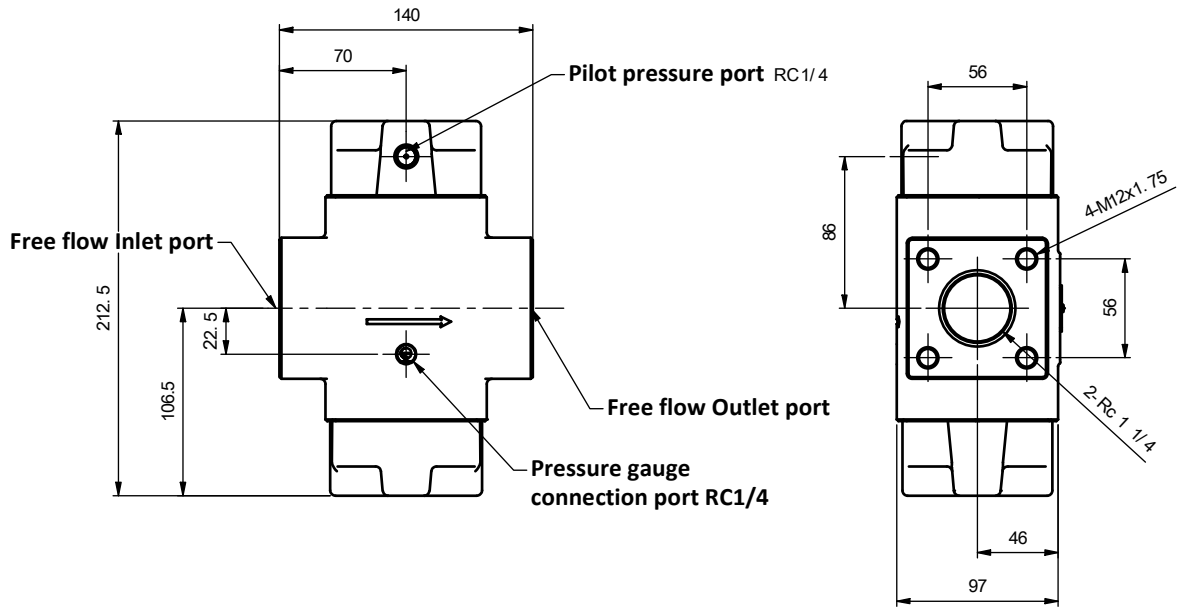

Directional Control Valves
Pilot Operated Check Valves

PVTI-03

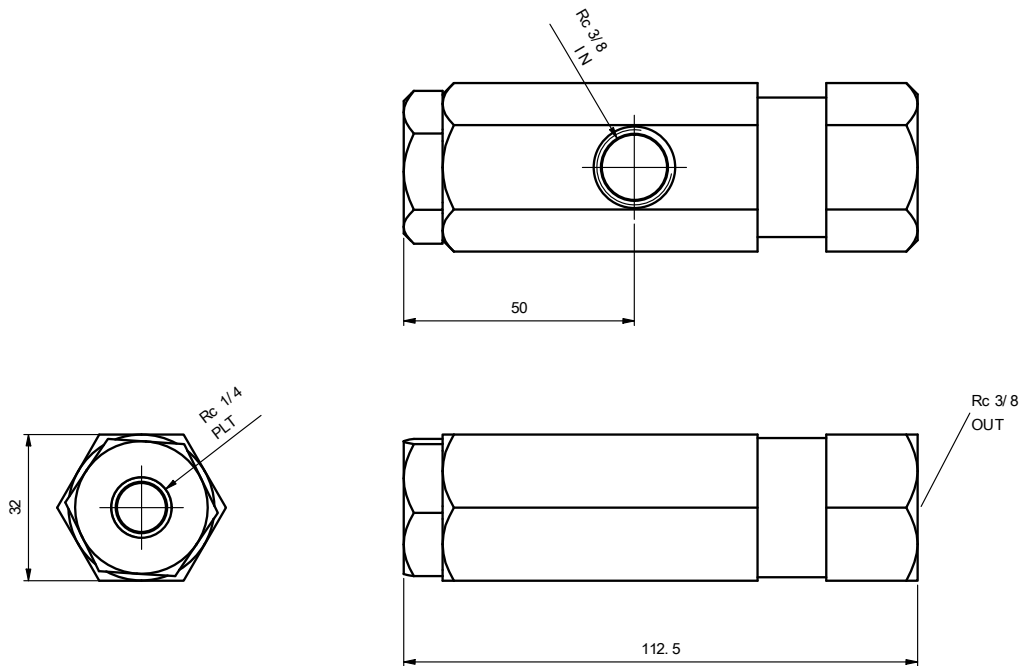

PVTI - 03

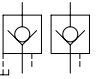

Directional Control Valves
Pilot Operated Check Valves

PF Series Prefill Valves



JIS-Graphic Symbol

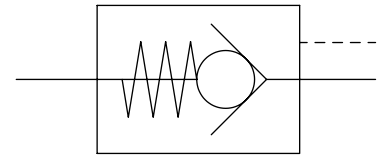

Feature

- Simple structure, Long service life, Easy installation.
- The internal force is shared by the three-arms, and the quality is reliable.
- Low pressure drops, Large flow.
- The prefill valve is small size with large flow and no leakage. Be sure to release the pressure before operating, otherwise it will not work.

Specification

Model	Thread Code Size (Inch)	Rated Flow (Max.) L/min	Operating Pressure (Max.) kgf/cm ²	Cracking Pressure Kgf/cm ²	Weight kg
PF-90	3-1/2"	630	250	34.2	11.8
PF-100	4"	1000		39.4	15.8
PDF-90	3-1/2"	630		34.2	11.8
PDF-100	4"	1000		39.4	15.8

Dimensions

PDF Series

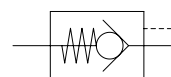
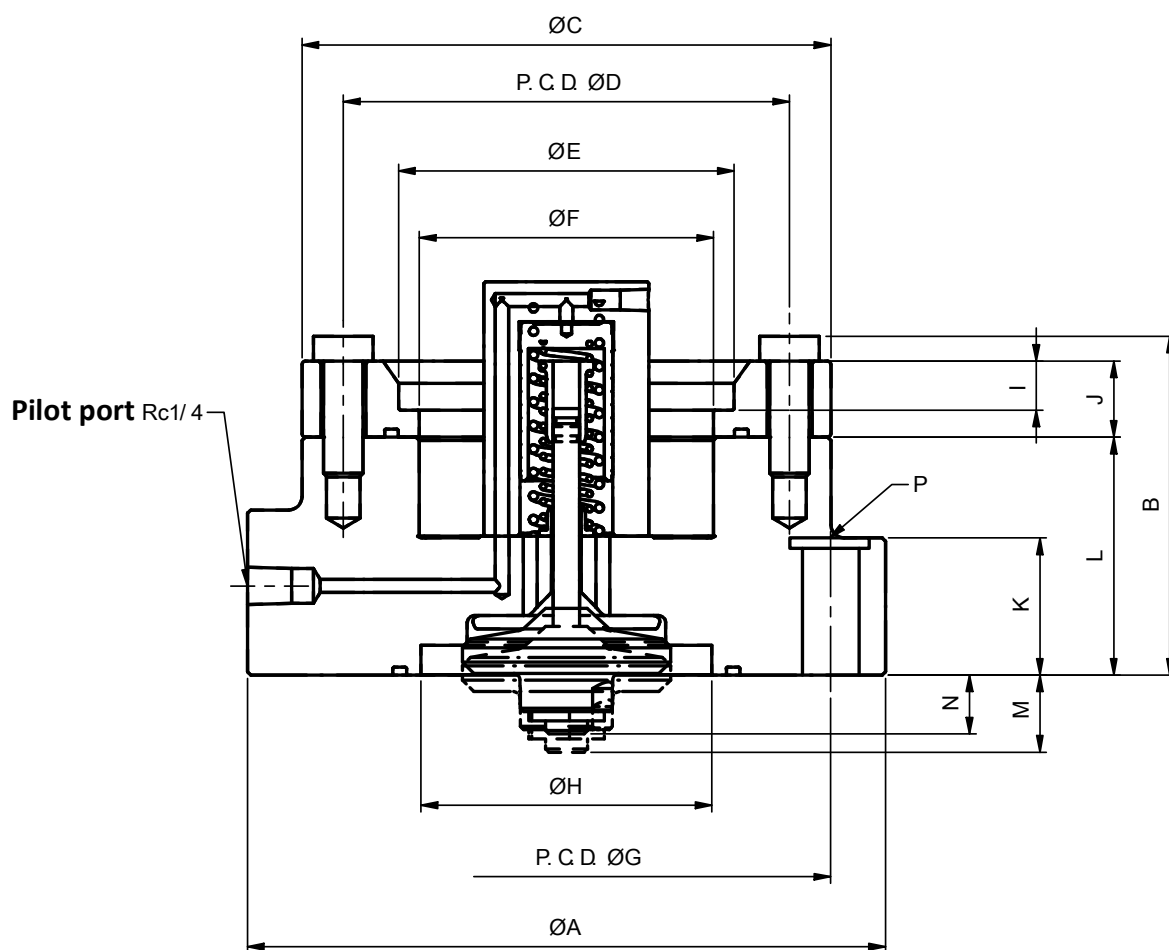

Directional Control Valves
PF Series Prefill Valves

Model	A	B	C	D	E	F	G	H	I	J	K	L	N	M	P
PDF-90	200	107.5	140	120	90	86	165	88	15	72.5	41.5	72.5	12.5	22	Ø20 Through M18 x 65
PDF-100	230	109	165	145	115.5	105	191	106	13	24.5	45	74	11	24	Ø21.5 Through M20 x 70

SG Series Prefill Valves



JIS-Graphic Symbol

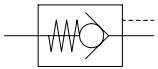
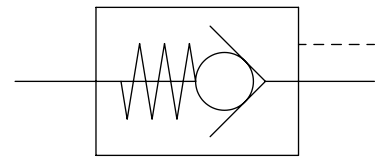

Feature

- The prefill valve is generally used as oil input and output between the hydraulic cylinder and the tank. In the fast stroke of large presses, the oil needs to be taken from the cylinder, and prevents the oil flowing from cylinder to the tank when pressurized, or the other way oil flow backs to the tank.
- Commonly used in large presses and injection molding machines as an oil supply tank; can use a small pump for fast movement. When the cylinder is running fast, it fills the cylinder with a large amount of oil from the tank. During pressurization, the return flow from the cylinder to the tank can be cut off. When the cylinder returns, the pilot control pressure forces the Prefill Valve to open and direct oil from the cylinder back to the tank.

Model Description

SG	-24	-LR
Model / Series	Thread Code Size (Inch)	Rotation Angle
SG Series Prefill Valves	16 : 2" 24 : 3" 32 : 4"	None: 180° degrees LR: 90° degrees

Specification

Model / Type	Operating Pressure (Max.) kgf/cm ²	Rated Flow (Max.) L/min		Operating Flow (Max.) L/min		Cracking Pressure kgf/cm ²	Weight kg
		Vacuum	PL On	Vacuum	PL On		
SG-16	210	300	450	300±70M	450±70M	0.12	30
SG-24	210	600	900	600±150M	900±150M	0.14	55
SG-32	210	1100	1600	1100±300M	1600±300M	0.16	105

Dimensions

SG - 16

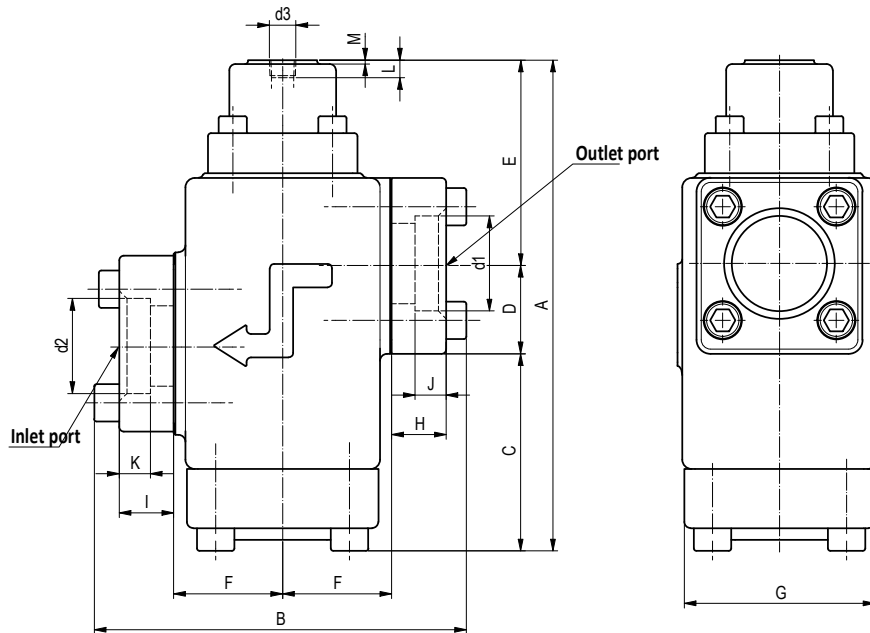

Model	A	B	C	D	E	F	G	H	I	K	K	L	M	d1	d2	d3
SG-16	338	242	138	50	150	70	123	35	24	20	20	21	12	61	61	3/8PT



SG-24/SG-32

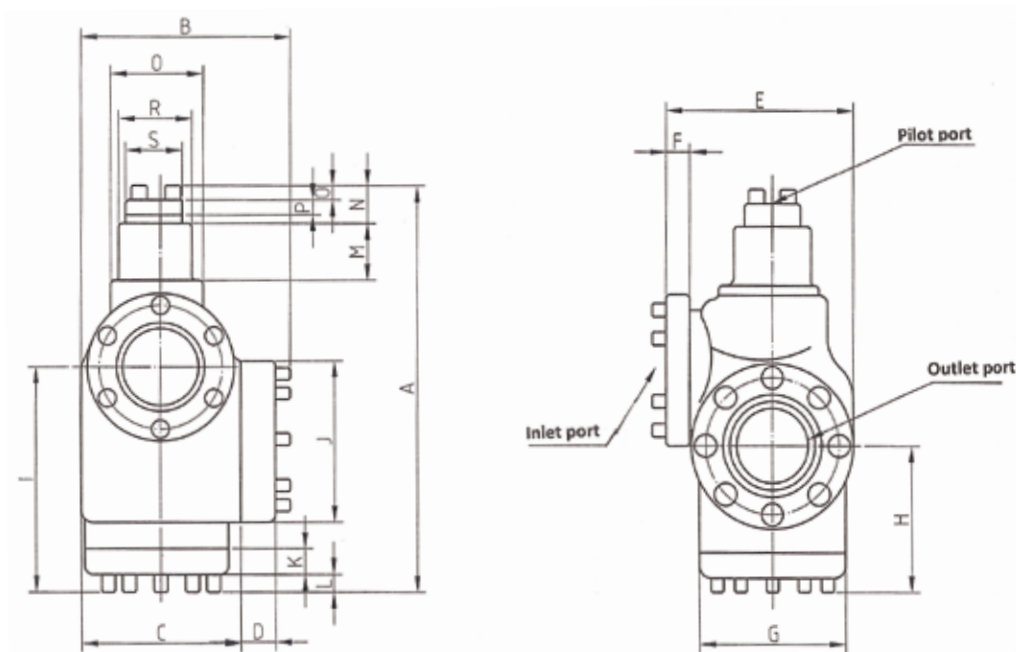

Model	A	B	C	D	E	F	G	H	I	J	K	L	M	N	O	P	Q	R	S
SG-24	402	260	200	42	230	30	155	160	235	140	40	16	96	-	-	-	120	67	3/8PT
SG-32	560	286	220	45	265	31	203	210	330	203	52	20	112	35	10	25	136	85	65

Directional Control Valves
 SG Series Prefill Valves

PHP Series Prefill Valves



JIS-Graphic Symbol

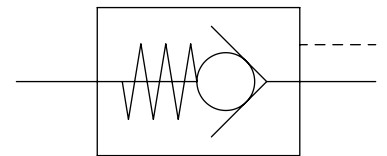

Specification

Model	Thread Code Size (Inch)	Operating Pressure (Max.)kgf/cm ²		Rated Flow (Max.) L/min		Cracking Pressure kgf/cm ²	
		CL side	R side	R-CL	CL-R	1	2
PHP-16	2"	250	20	160	320	0.5	1.5
PHP-20	2 1/2"			320	640		

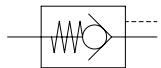

Dimensions

PHP-16

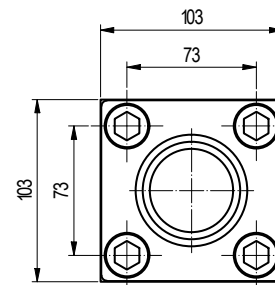
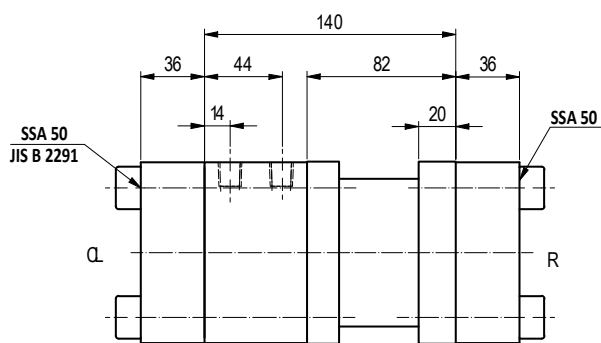
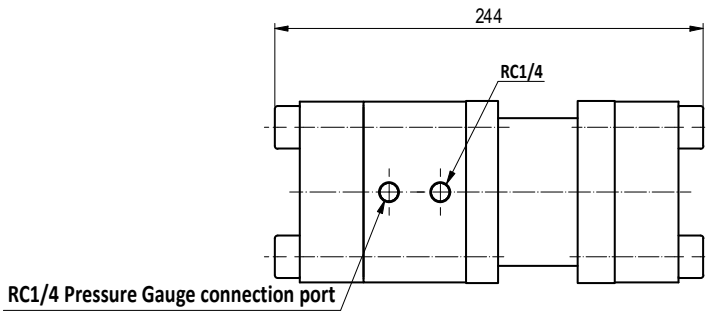

PHP-20

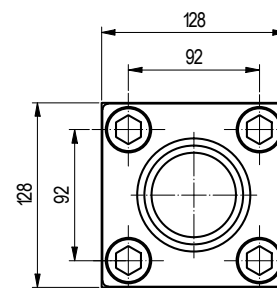
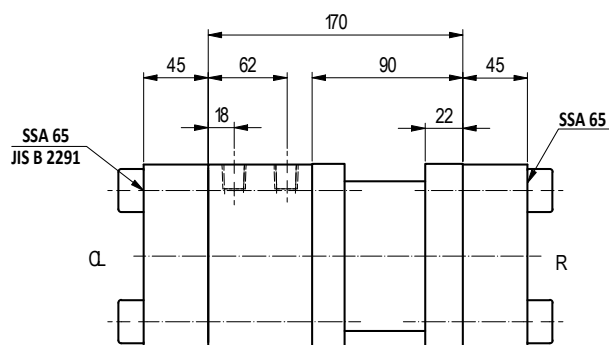
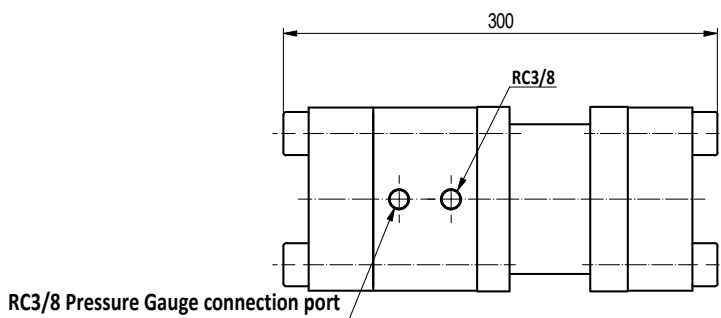

Directional Control Valves
PHP Series Prefill Valves

Solenoid Operated Poppet Type Two-Way Valves



JIS-Graphic Symbol

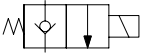
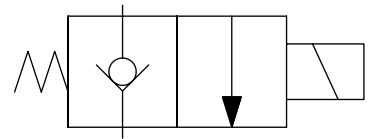

Model Description

V2066	-A22	-OM
Model /Series	Coil Type	Manual Operating

Solenoid Operated Poppet Type Two-Way Valves	D12 : DC12V	None: Standard Type OM: With Manual Type
	D24 : DC24V	
	A24 : AC24V	
	A11 : AC110V	
	A22 : AC220V	
	A38 : AC380V	

Specification

Model	Normally Closed (NC)		Normally Open (NO)		Rated Flow (Max.) L/min	Weight Kg	Operation Pressure (Max.) kgf/cm ²	Operation Temperature °C	Connection Type
	One-Way	Two-Way	One-Way	Two-Way					
V2066	•	•	-	-		0.2			
V2067	•	•	•	•	20	0.5			
V2068	•	•	-	-		0.5			
V3066	•	•	•	•		0.4	210	-20~120	*Plug Type *Wire Type (2-wires)
V3067	•	•	-	-	40	0.7			
V3068	•	•	-	-		0.5			
V6067	•	•	-	-	80	1.6			
V6068	•	•	-	-		0.8			

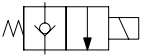



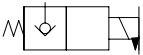







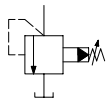

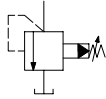

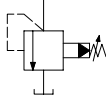
Directional Control Valves
Solenoid Operated Poppet Type
Two-Way Valves

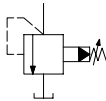

Directional Control Valves
Solenoid Operated Poppet Type
Two-Way Valves

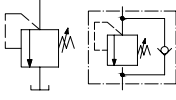
B

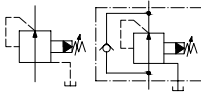
Pressure Control Valves

ITEM PICTURE	JIS GRAPHIC SYMBOL	PRODUCT NAME	PAGE
		Direct Type/Remote Control Relief Valves	2
		Pilot Operated Relief Valves	6
		Low Noise Type Pilot Operated Relief Valves	10
		Solenoid Controlled Pilot Operated Relief Valves	12
		Low Noise Type Solenoid Controlled Pilot Operated Relief Valves	16
		Multi-Functional Pressure Control Valves	18
		Pressure Reducing Valves	24
		Counterbalance Valves	30

Direct Type/ Remote Control Relief Valves



JIS-Graphic Symbol

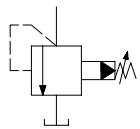
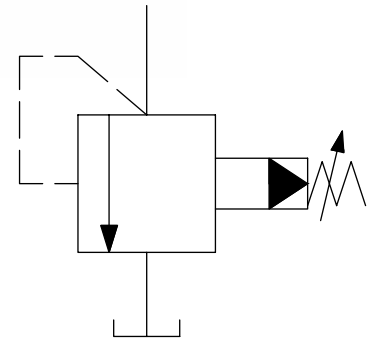

Feature

- Remote-control series can be used for remote control and multi-stage pressure control.
- Direct-control series can be used as a safety valve in small flow system.

Model Description

D	G	-01	-3
Model /Series	Installation Type	Thread Code Size (Inch)	Pressure Adjustment Range Kgf/cm ²
Remote Control	G : Sub-Plate Mounting T : Treaded Connection	01 : 1/8"	1 : 10-70 2 : 35-140 3 : 70-210
Direct Type	G : Sub-Plate Mounting T : Treaded Connection	02 : 1/4"	

Specification

Model /Type		Operating Pressure (Max.) Kgf/cm ²	Operating Pressure (Max.) Kgf/cm ²	Rated Flow (Max.) L/min
Remote Control	D*-01-1	250	7-70	2
	D*-01-2		35-140	
	D*-01-3		70-210	
Direct Type	D*-02-1	250	7-70	16
	D*-02-2		35-140	
	D*-02-3		70-210	

Dimensions

DT-01

Dimensions are the same except for port size and position.

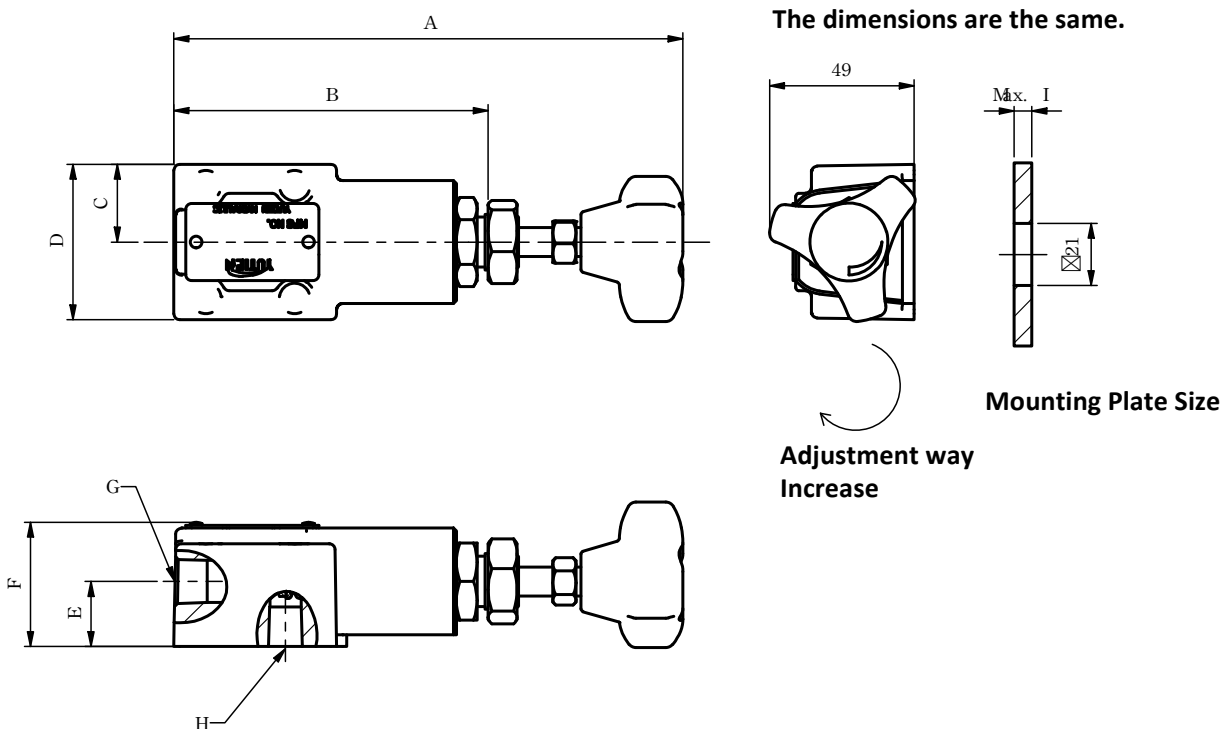
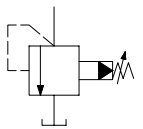

Model	A	B	C	D	E	F	G	H	I
DT-01	185	107	26.5	53	23	43	Rc 3/8	Rc 1/4	4
DT-02	195	116	26	52	28	49	Rc 1/4	Rc 1/4	7

Pressure Control Valves
 Direct Type/Remote Control Valves

Dimensions

DG-01

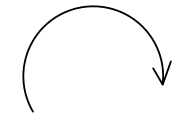
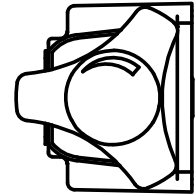
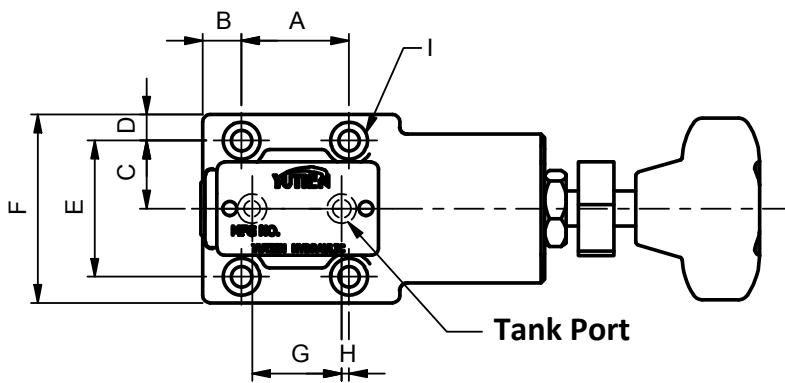

Adjustment way
Increase

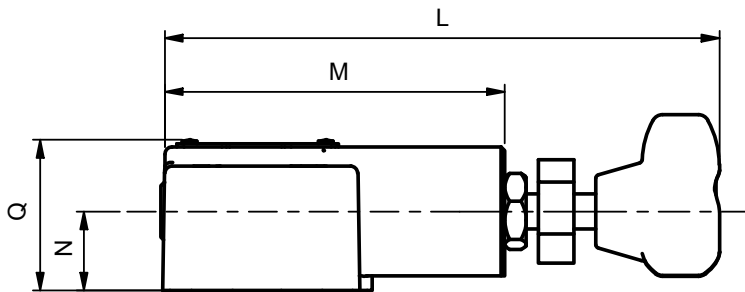

Model	A	B	C	D	E	F	G	H
DG-01	30	11.5	19	7.5	38	53	25	2
DG-02	30	12	19	6.5	38	51	25	2

Model	I	L	M	N	Q
DG-01	Ø5.5 Through	185	96	36.5	43
DG-02	Ø5.5 Through	195	101	39	49

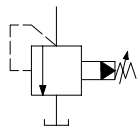

Pressure Control Valves
Direct Type/Remote Control Valves

B

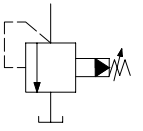

Pressure Control Valves Direct Type/Remote Control Valves

Pilot Operated Relief Valves



JIS-Graphic Symbol

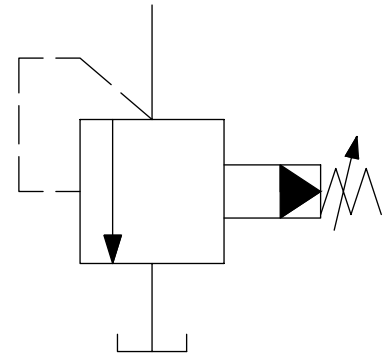

Feature

- RV series relief valve use a pilot-operated design with low noise, which can keep the pressure stable in the system, and can realize remote control and unloading.

Model Description

RV	G	H	-03	S	-3
Model /Series	Installation Type	Functional	Thread Code Size (Inch)	Appearance	Pressure Adjustment Range Kg/cm ²

Pilot Operated Relief Valves	G: Sub-Plate Mounting	None: Standard	01 : 1/8" (circle)	None: Normal Type S: One-Piece Type	1 : 7-70 2 : 35-140 3 : 70-250
	T: Threaded Connection	H: High Flow	02 : 1/4" (circle)		
		P: Plate Mounting	03 : 3/8"		
			04 : 1/2"		
			06 : 3/4" 10 : 1-1/4"		

Specification

Model /Type	Operating Pressure (Max.) Kg/cm ²	Pressure Adjustment Range Kg/cm ²	Rated Flow (Max.) L/min
RVG-03 RVT-04	250	1 : 7-70 2 : 35-140 3 : 70-250	100
RVG-06 RVT-06			200
RVG-10 RVT-10			400

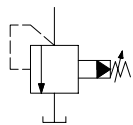

Instructions

- **Pressure Adjustment:** When adjusting the pressure, loosen the lock nut, turn the handle slowly, clockwise is the pressure increase, counterclockwise is the pressure decrease, please don't forget to tighten the fixing nut after the adjustment.
- **Oil return method:** The oil pipes of the direct-controlled type and remote-controlled type should not connect with other valves but should be directly connected to the tank. If the internal volume in the oil pipes is too large, buffeting is likely to occur. Therefore, the length and diameter of the piping should be minimized.
- **Flow selection:** When the flow is small, the adjustment pressure will be unstable. When using threaded code size 03 and 06, the flow rate should be greater than 5L/min, When using threaded code size 10, the flow rate should be greater than 8L/min.

Dimensions

RVG-03/06/10

RVG-03 : ISO 6264-AR-06-2-A

RVG-06 : ISO 6264-AS-08-2-A

RVG-10 : ISO 6264-AT-10-2-A

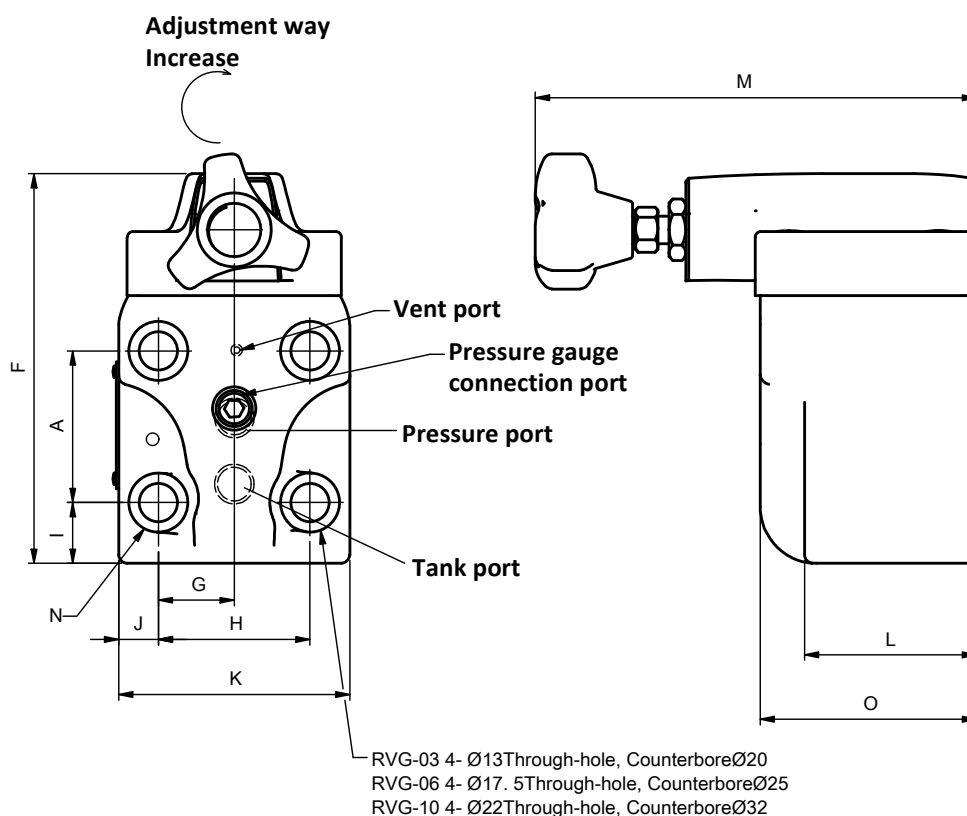

Model	A	F	G	H	I	J	K	L	O	M
RVG-03	53.8	139	26.9	53.8	18	14.6	83	59.5	77	178
RVG-06	66.7	167	35	70	18	16	102	40	78.5	178
RVG-10	88.9	198	41.3	82.6	21	20.5	124	50	83	180

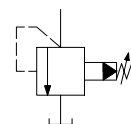

Pressure Control Valves
Pilot Operated Relief Valves

Dimensions

RVT-04/06/10

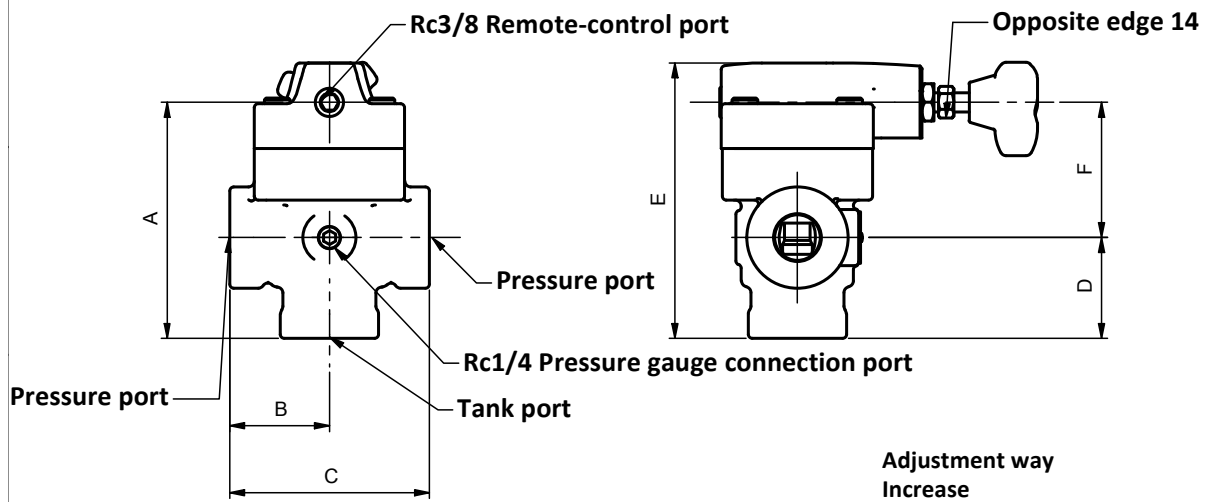
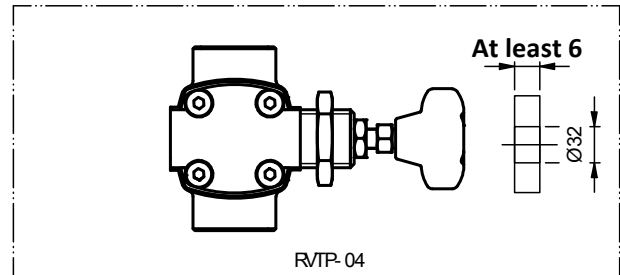

Adjustment way
Increase

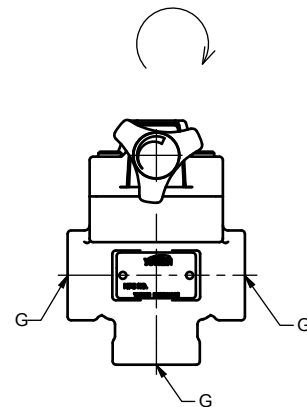

Model	A	B	C	D	E	F	G
RVT-04	109	47	94	44.5	127	62.5	Rc 1/2
RVT-06	119.5	50	100	48.5	142	60.5	Rc 3/4
RVT-10	157	65	130	68	175	89	Rc 1 1/4

B

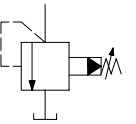

Pressure Control Valves Pilot Operated Relief Valves

Low Noise Type Pilot Operated Relief Valves



JIS-Graphic Symbol

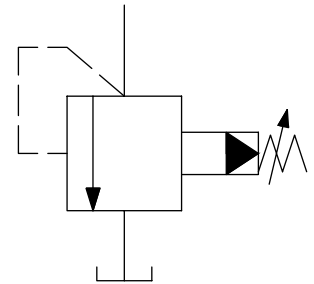

Feature

- SBG series is a low noise pressure valve, which is used to control hydraulic system pressure to keep constant, and to prevent overpressure of the pump. The remote-control port can achieve remote-control and unloading.

Model Description

SB	G	-06	-3
Model /Series	Installation Type	Thread Code Size (Inch)	Pressure Adjustment Range Kg/cm ²
Low Noise Type Pilot Operated Relief Valves	G: Sub-Plate Mounting	03 : 3/8" 06 : 3/4" 10 : 1 1/4"	1 : 7-70 2 : 35-140 3 : 70-250

Specification

Model /Type	Operating Pressure (Max.) Kg/cm ²	Pressure Adjustment Range Kg/cm ²	Rated Flow (Max.) L/min
SBG-03	310	1 : 7-70	100
SBG-06		2 : 35-140	200
SBG-10		3 : 70-250	400

Note: The pressure range of 25~32Mpa is only for transient pressure and cannot be used as normal pressure.

B

Pressure Control Valves
Low Noise Type Pilot Operated Relief Valves

Instructions

- **Pressure Adjustment:** When adjusting the pressure, loosen the lock nut, turn the handle slowly, clockwise is the pressure increase, counterclockwise is the pressure decrease, please don't forget to tighten the fixing nut after the adjustment.
- **Oil return method:** The oil pipes of the direct-controlled type and remote-controlled type should not connect with other valves but should be directly connected to the tank. If the internal volume in the oil pipes is too large, buffeting is likely to occur. Therefore, the length and diameter of the piping should be minimized.
- **Flow selection:** When the flow is small, the adjustment pressure will be unstable. When using threaded code size 03 and 06, the flow rate should be greater than 5L/min, When using threaded code size 10, the flow rate should be greater than 8L/min.

Dimensions

SBG-03/06/10

SBG-03 : ISO 6264-AR-06-02-A
 SBG-06 : ISO 6264-AS-08-02-A
 SBG-10 : ISO 6264-AT-10-02-A

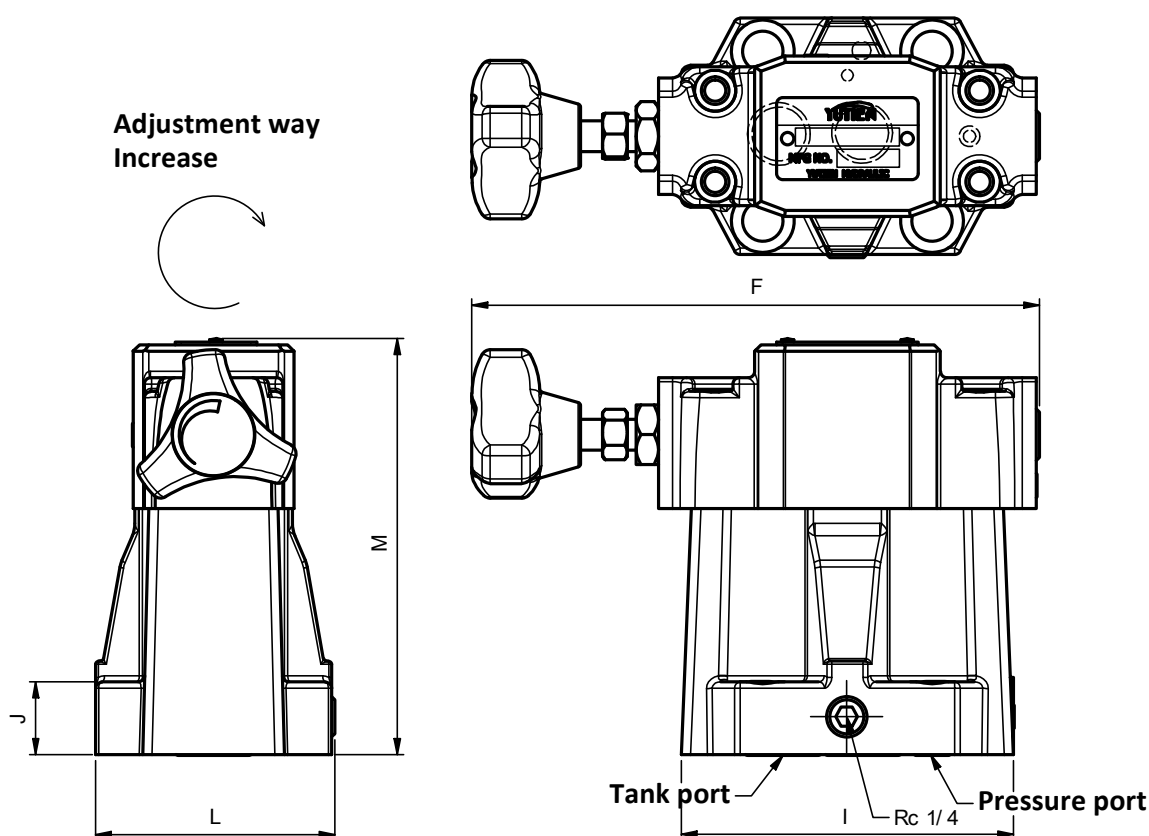

Model	F	I	J	L	M
SBG-03-L	190	107	19	78	132
SBG-06-L	190	122.5	29.5	98.5	133
SBG-10-L	198	154	38	121	145

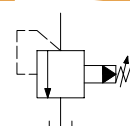

Pressure Control Valves
 Low Noise Type Pilot Operated Relief Valves

Solenoid Controlled Pilot Operated Relief Valves



JIS-Graphic Symbol

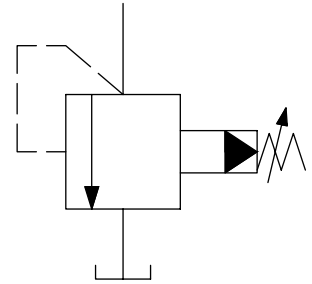

Feature

- The combination of the relief valve and the solenoid operated directional valve, since the solenoid valve is directly installed on the relief valve, and is linked to the vent port, thus it does not require extra relief pipes. Pump pressure can

be remotely unloaded by the electronic signal from the solenoid valve or adjusted by connecting a pilot relief valve to the solenoid valve port. The system gets variable-pressure or three-stage pressure control.

Model Description

RV	G	S	-06	-3	-2P	A1
Model /Series	Installation Type	Solenoid Control (Optional)	Thread Code Size (Inch)	Pressure Adjustment Range Kg/cm ²	Control Type	Coil Type (Solenoid Valve) (Optional)

Solenoid Controlled Pilot Operated Relief Valves	G: Sub-Plate Mounting T: Threaded Connection	None: Not Required S: Solenoid Valve	03 : 3/8" 04 : 1/2" 06 : 3/4" 10 : 1-1/4"	1 : 7-70 2 : 35-140 3 : 70-250	Please refer hydraulic circuits (p.B13)	None: No Coil A1 : AC110V A2 : AC220V A3 : AC380V D1 : DC12V D2 : DC24V
--	---	---	--	--------------------------------------	---	--

Specification

Model /Series	Operating Pressure (Max.) Kg/cm ²	Pressure Adjustment Range Kg/cm ²	Rated Flow (Max.) L/min
RVGS-03-*	250	1 : 7-70	100
RVGS-06-*		2 : 35-140	200
RVGS-10-*		3 : 70-250	400

Note: The relief valve can be a standard pilot relief valve.

The minimum pressure range and the other features can refer to the series of direct-control relief valve.

B

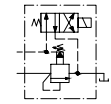

Pressure Control Valves
 Solenoid Controlled Pilot Operated Relief Valves

Hydraulic Control Circuits

Model	Input Electrical Signal		Pressure Setting	Pressure Stage	Solenoid-controlled DSW Series (Optional)
	Sol.a	Sol.b			
1PN	-	Off	No-load	Single stage	DSW-02-2B3B (DSW-02-2B2)
	-	On	Relief Valve setting pressure		
1P	Off	-	Relief Valve setting pressure	Single stage	DSW-02-2B2 (Reverse)
	On	-	No-load		
2P	Off	-	Pressure A	Two-stage	
	On	-	Pressure B		
2PN	Off	Off	No-load	Two-stage	DSW-02-3C6 DSW-02-3C3
	On	Off	Pressure A		
	Off	On	Pressure B		
3P	Off	Off	Pressure N	Three-stage	
	On	Off	Pressure A		
	Off	On	Pressure B		

Dimensions

RVGS-**-1P

RVGS-03 : ISO 6264-AR-06-2A
RVGS-06 : ISO 6264-AS-08-2A
RVGS-10 : ISO 6264-AT-10-2A

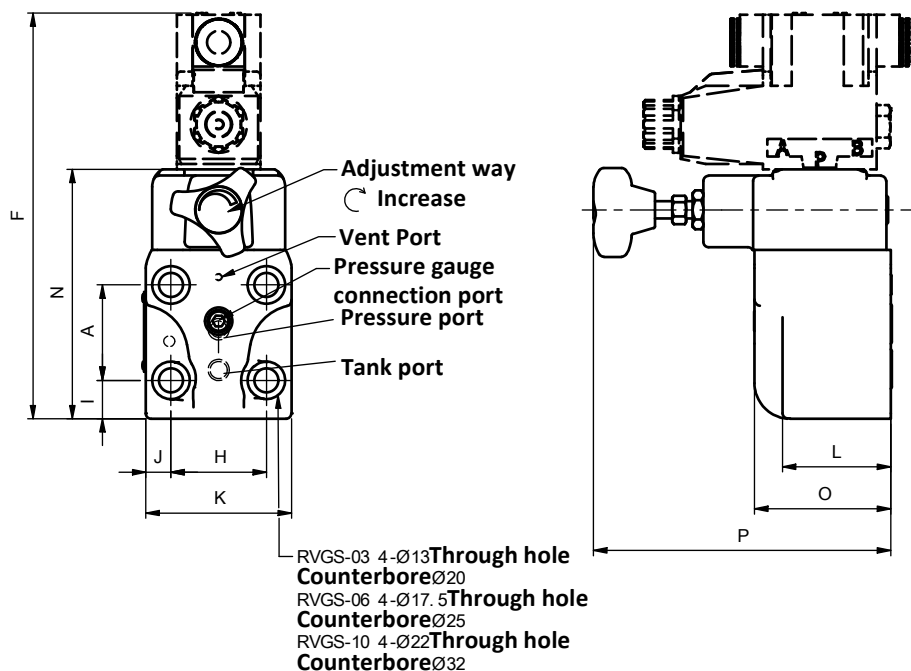

Model	A	F	H	I	J	K	L	N	O	P
RVGS-03	53.8	224	53.8	18	14.6	83	59.5	137	77	178
RVGS-06	66.7	252	70	18	16	102	40	165	78.5	178
RVGS-10	88.9	290.5	82.6	21	20.5	124	50	203.5	83	182

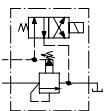

Pressure Control Valves
 Solenoid Controlled Pilot
 Operated Relief Valves

Dimensions

RVGS-**-2P/2PN

RVGS-03 : ISO 6264-AR-06-2A
RVGS-06 : ISO 6264-AS-08-2A
RVGS-10 : ISO 6264-AT-10-2A

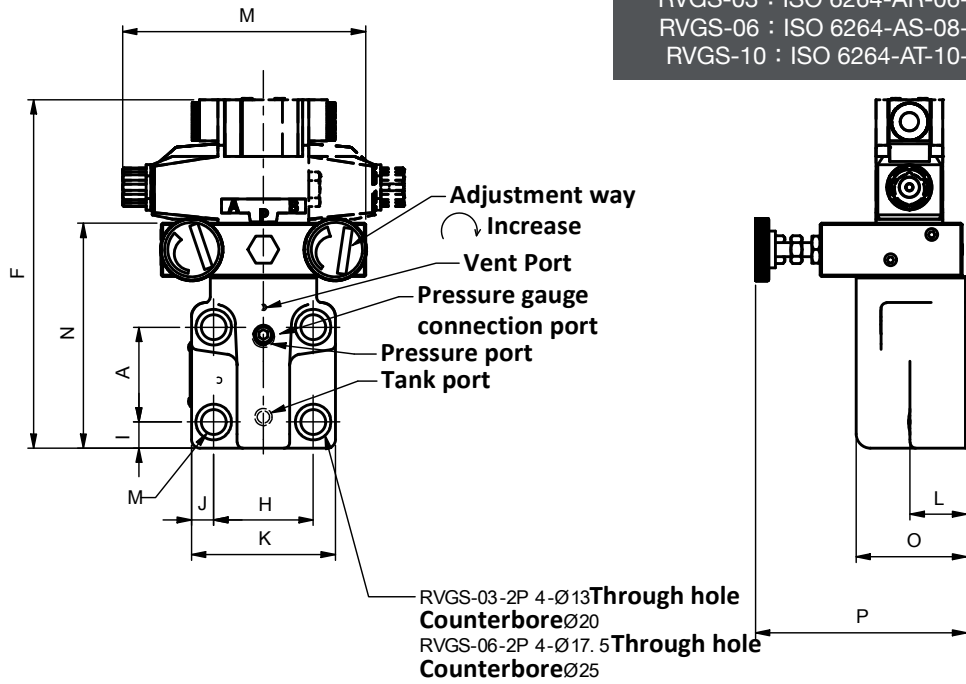

Model	A	F	H	I	J	K	L	M	N	O	P
RVGS-03-2P	53.8	224	53.8	18	14.6	83	59.5	172	137	77	160
RVGS-06-2P	66.7	252	70	18	16	102	40	172	165	78.5	160

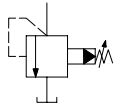

Pressure Control Valves
 Solenoid Controlled Pilot
 Operated Relief Valves

Dimensions

RVGS-**-3P

RVGS-03 : ISO 6264-AR-06-2A
RVGS-06 : ISO 6264-AS-08-2A
RVGS-10 : ISO 6264-AT-10-2A

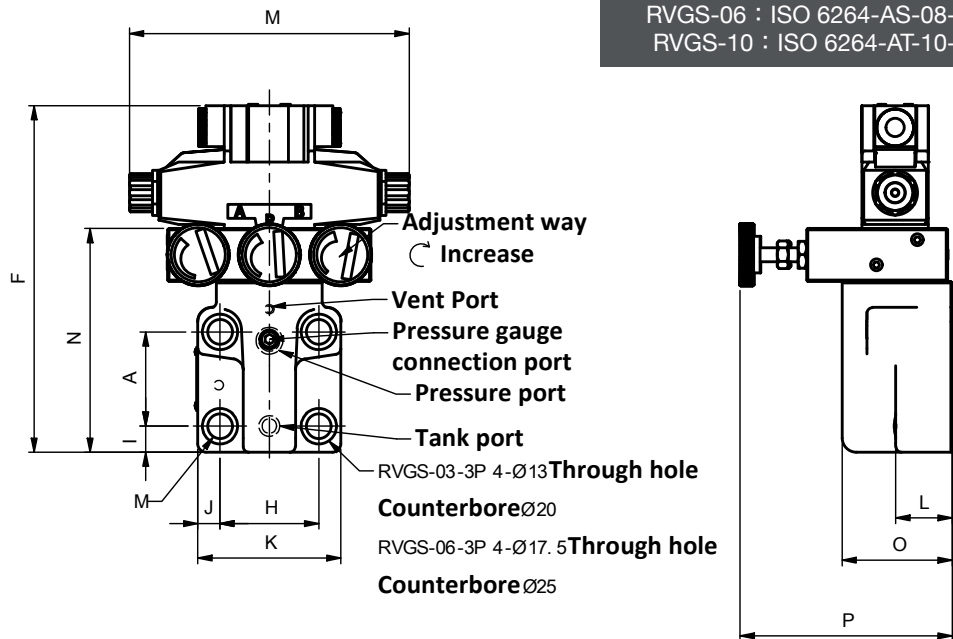

Model	A	E	F	H	I	J	K	L	M	N	O	P
RVGS-03-2P	53.8	0	224	53.8	18	14.6	83	59.5	200	137	77	160
RVGS-06-2P	66.7	23.8	252	70	18	16	102	40	200	165	78.5	160

Dimensions

RVTS-06

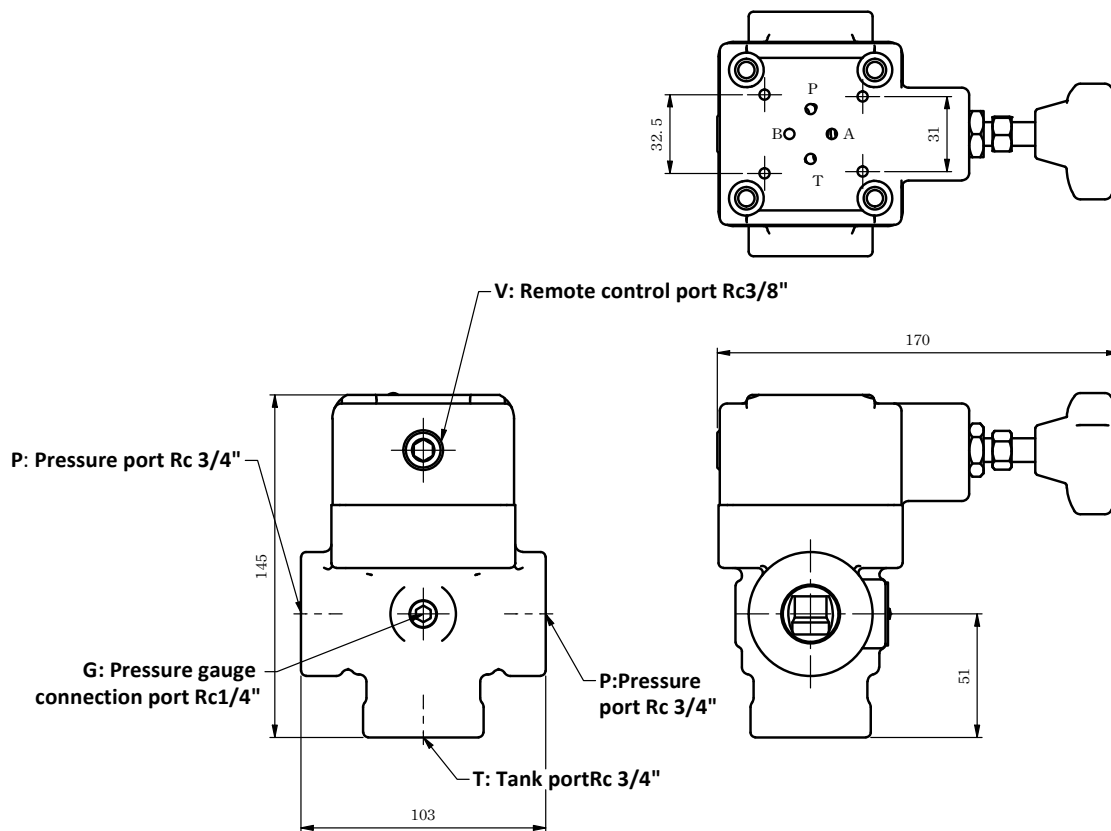

RVTS-10

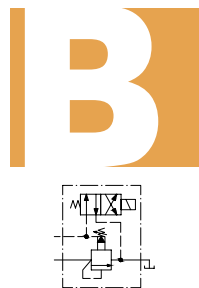
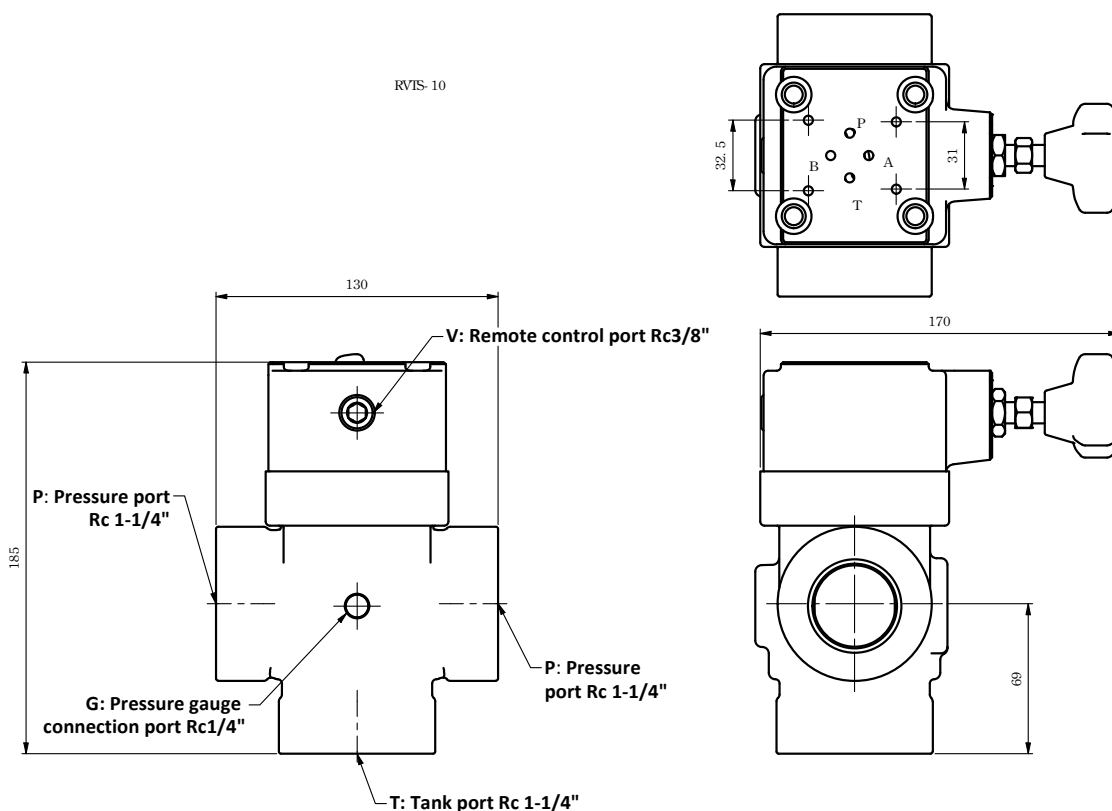

Pressure Control Valves
Solenoid Controlled Pilot
Operated Relief Valves

Low Noise Solenoid Controlled Pilot Operated Relief Valves



JIS-Graphic Symbol

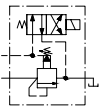
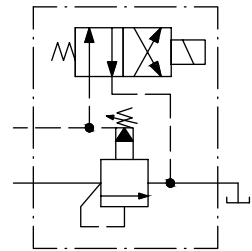

Feature

- Combination of low noise pilot relief valve and solenoid operated directional valve. In addition to the feature of the SBG series. Pump pressure can be remotely unloaded by the electronic signal

from the solenoid valve or adjusted by connecting a pilot relief valve to the solenoid valve port. The system gets two or three-stage pressure control.

Model Description

SBS	G	-06	-1P	-3	-A2
Model /Series	Installation Type	Thread Code Size (Inch)	Control Type	Pressure Adjustment Range Kgf/cm ²	Coil Type (Solenoid Valve) (Optional)
Low Noise Solenoid Controlled Pilot Operated Relief Valves	G: Sub-Plate Mounting	03 : 3/8" 06 : 3/4" 10 : 1-1/4"	1P: Normally No-load 1PN: Normally Pressure Setting 2P: Dual Pressure Setting	1 : 7-70 2 : 35-140 3 : 70-250	A1 : AC110V A2 : AC220V A3 : AC380V D1 : DC12V D2 : DC24V

Specification

Model /Type	Operating Pressure (Max.) Kgf/cm ²	Pressure Adjustment Range Kgf/cm ²	Rated Flow (Max.) L/min
SBSG-03	310	1 : 7-70 2 : 35-140 3 : 70-250	100
SBSG-06			200
SBSG-10			400

Note: The pressure range of 25~32Mpa is only for transient pressure and cannot be used as normal pressure.

Pressure Control Valves
Low Noise Solenoid Controlled Pilot Operated Relief Valves

Hydraulic Control Circuits

Model	Input Electrical Signal		Pressure Setting	Pressure Stage	Solenoid-controlled DSW Series (Optional)
	Sol.a	Sol.b			
1PN	—	Off	No-load	Single-stage	DSW-02-2B3B (DSW-02-2B2)
	—	On	Relief Valve setting pressure		
1P	Off	—	Relief Valve setting pressure	Single-stage	DSW-02-2B2(Reverse) Requires use with SRDV series control valve.
	On	—	No-load		
2P	Off	—	Pressure A	Two-stage	
	On	—	Pressure B		

Dimensions

SBSG-**

SBSG-03 : ISO 6264-AR-06-02-A
SBSG-06 : ISO 6264-AS-08-02-A
SBSG-10 : ISO 6264-AT-10-02-A

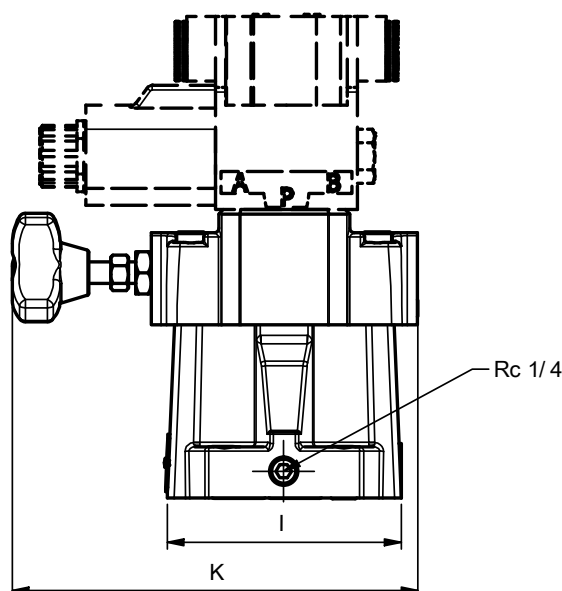
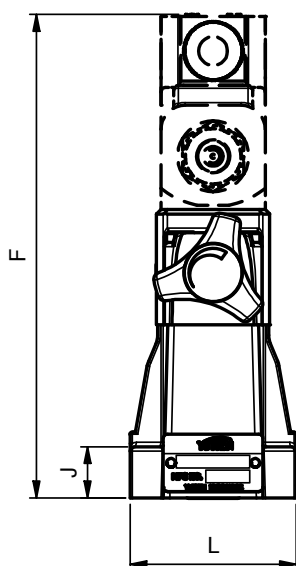
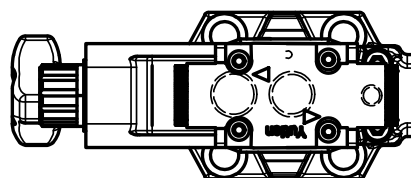

Pressure Control Valves
Low Noise Solenoid Controlled Pilot Operated Relief Valves

Model	F	I	J	K	L
SBSG 03-L	219	107	19	190	78
SBSG 06-L	220	122.5	29.5	190	98.5
SBSG 10-L	232	154	38	198	121

Multi-Functional Pressure Control Valves



JIS-Graphic Symbol

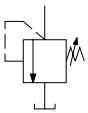
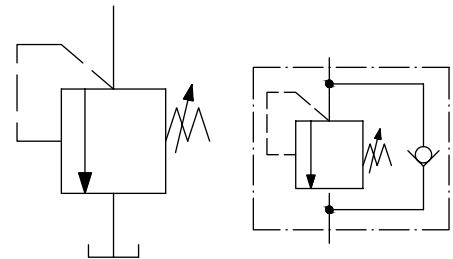

Feature

- This is a direct-acting pressure control valve, which can be operated by internal or external control pressure.
- The type of valve can be divided into low-pressure relief valve, unloading valve, sequence valve.

Model Description

U	C	G	-03	-3	IE
Model /Series	Check Function	Installation Type	Thread Code Size(Inch)	Pressure Adjustment Range Kg/cm ²	Pilot / Drain Types

Multi-Functional Pressure Control Valves

None: Not Required
C: Check Valve

G: Sub-Plate Mounting
T: Threaded Connection

03 : 3/8"
06 : 3/4"
10 : 1 1/4"

1 : 5 - 35
2 : 35 - 70
3 : 70 - 140
4 : 140 - 210

II: Internal Pilot-Internal drain
IE: Internal Pilot-External drain
EE: External Pilot-External drain
EI: External Pilot-Internal drain

Specification

Model /Type	Operating Pressure (Max.) Kg/cm ²	Pressure Adjustment Range Kg/cm ²	Rated Flow (Max.) L/min
U**-03	210	1 : 5-70	60
U**-06		2 : 35-140	120
U**-10		3 : 70-210 4 : 140~210	240

Valve Type

(U) Valve	II: Low-Pressure Relief Valve	IE: Sequence Valve	EE: Sequence Valve	EI: Unloading Valve
Pilot / Drain Type	Internal Pilot-Internal drain	Internal Pilot-External drain	External Pilot-External drain	External Pilot-Internal drain
Operations				
JIS-Graphic Symbol				

Instructions	<p>When the internal pilot pressure exceeds the pressure setting, the balance piston rises. The primary and secondary pressure circuits are opened, and the secondary pressure is connected to the tank and becomes a direct relief valve. This valve is installed with very few hydraulic circuits.</p>	<p>This sequence of actions is based on two or more differences in the hydraulic circuit. This valve is internal pilot pressure operate in sequence, if you want to use the pressure to reverse the free flow back to the primary pressure, you should use a sequence valve with a check.</p>	<p>External pilot and drain operation, which acts the same as a sequence valve (IE) type.</p>	<p>This valve is the most used of the four types. The combined output of the high-flow low-pressure pump and the small-flow high-pressure pump makes the hydraulic cylinder move quickly. When the hydraulic cylinder reaches a higher pressure, the pressure of the high-pressure pump pilot unloading valve causes the balance piston to rise. The flow is drained back to the tank by the low-pressure pump, with no load on the pump.</p>
--------------	--	---	---	---

B

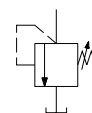

(UC) Valve Check Valve	II: Counterbalance Valve	IE: Sequence Valve (With Check Valve)	EE: Sequence Valve (With Check Valve)	EI: Counterbalance Valve
Pilot / Drain Type	Internal Pilot-Internal drain	Internal Pilot-External drain	External Pilot-External drain	External Pilot-Internal drain
Operations				
JIS-Graphic Symbol				

Instructions	<p>The counterbalance valve is also known as back pressure valve. When the vertical hydraulic cylinder has a heavy load, it will automatically descend, or the descending speed exceeds the control. This valve can apply back pressure to the hydraulic cylinder, which reduces the load balance. When the hydraulic cylinder rises, the built-in check valve can be used to reverse the flow direction.</p>	<p>When there is more than one hydraulic circuit, this valve can make two or more hydraulic cylinders operate in sequence according to the pressure of the internal pilot, with a check valve inside, the flow in the reverse direction, so the valve system is pilot internally, and the Cylinder-A is actuated Cylinder-B can also be actuated at the same time.</p>	<p>The valve function is the same as the (IE) type, with a check valve inside, and the flow can also be reversed. When the A-cylinder work is completed, the external pilot makes the B-cylinder start to work.</p>	<p>The valve function is the same as the (II) type, with a check valve inside, and the flow can also be reversed. When the speed of the hydraulic cylinder is fast or the load is unstable, the action will be unbalanced, so it is not often used.</p>
--------------	---	--	---	---

Pressure Control Valves

Multi-Functional Pressure Control Valves

Note:

- When adjusting the pressure, loosen the lock nut, turn the handle slowly, clockwise is the pressure increase, counterclockwise is the pressure decrease, please don't forget to tighten the fixing nut after the adjustment.
- The secondary pressure outlet of the internal drain and the external drain are needs to with a low back pressure that close to the atmospheric pressure, and directly return to the tank.

Dimensions

UT-03/06/10

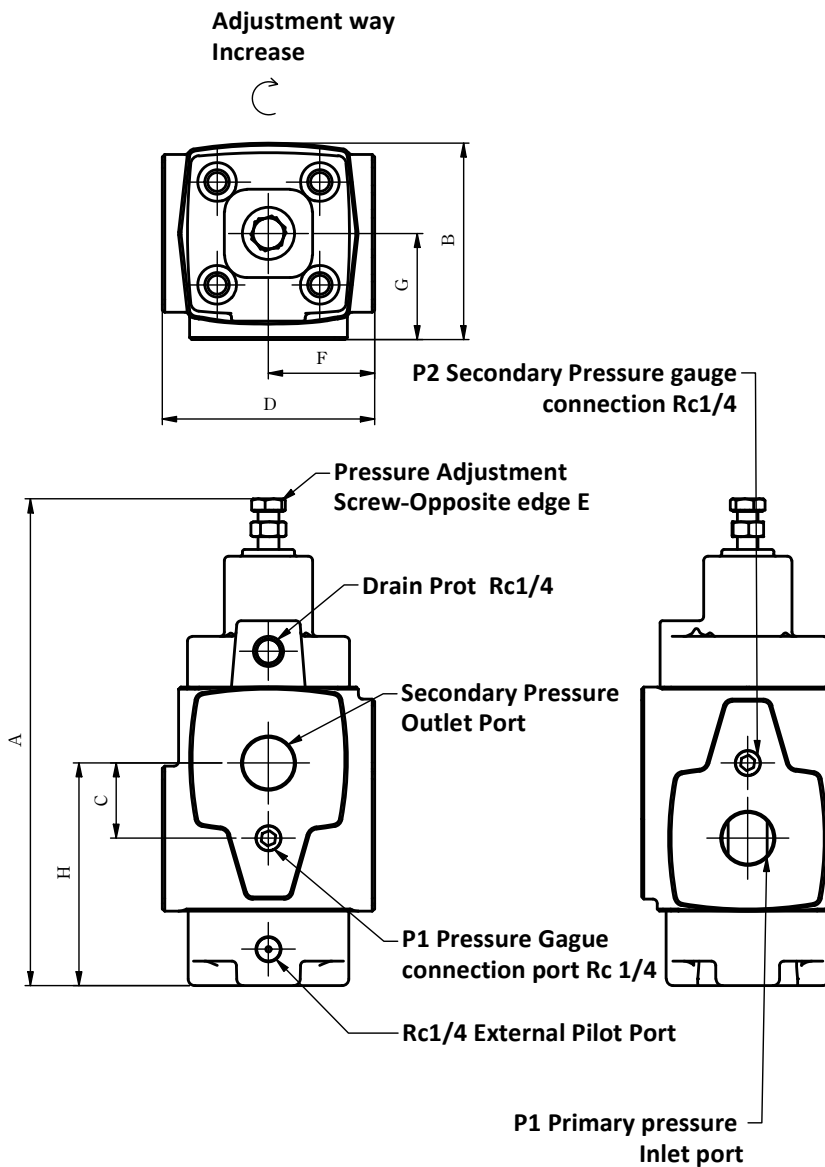

Model	A	B	C	D	E	F	G	H
UT-03	201	74	28	82	12	41	42	88.5
UT-06	231	87	35	95	14	47.5	50	100
UT-10	274	113	41	134	17	66.8	64	129

Dimensions

UCT-03/06/10

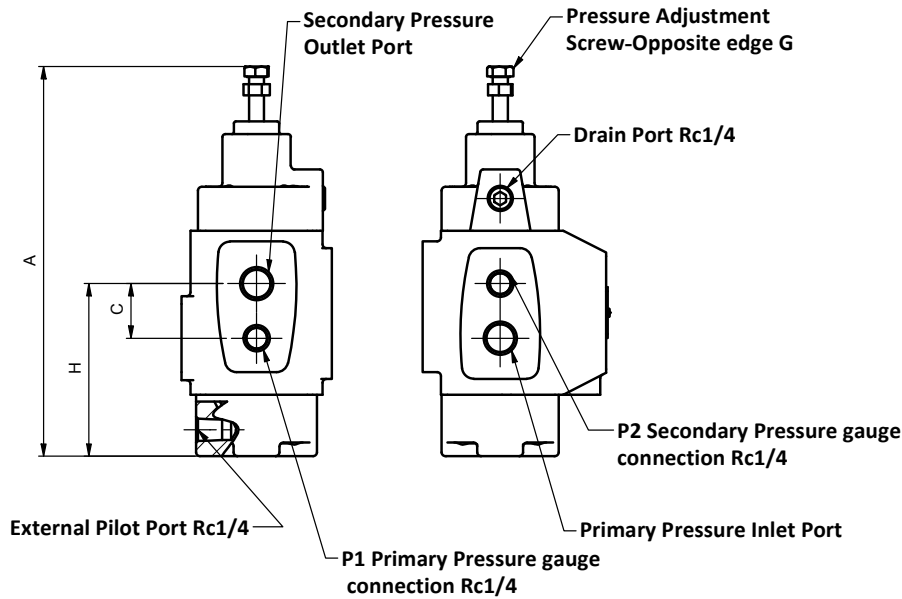

Model	A	B	C	D	E	F	G	H
UCT-03	200	95.5	29	79	40.5	40.5	12	89.5
UCT-06	229	116.5	34	97	48.5	48.5	14	100
UCT-10	272	164	45	135.5	65.5	68	17	131

UG-03/06

UG-03 : ISO 5781-AG-06-2-A
UG-06 : ISO 5781-AH-08-2-A

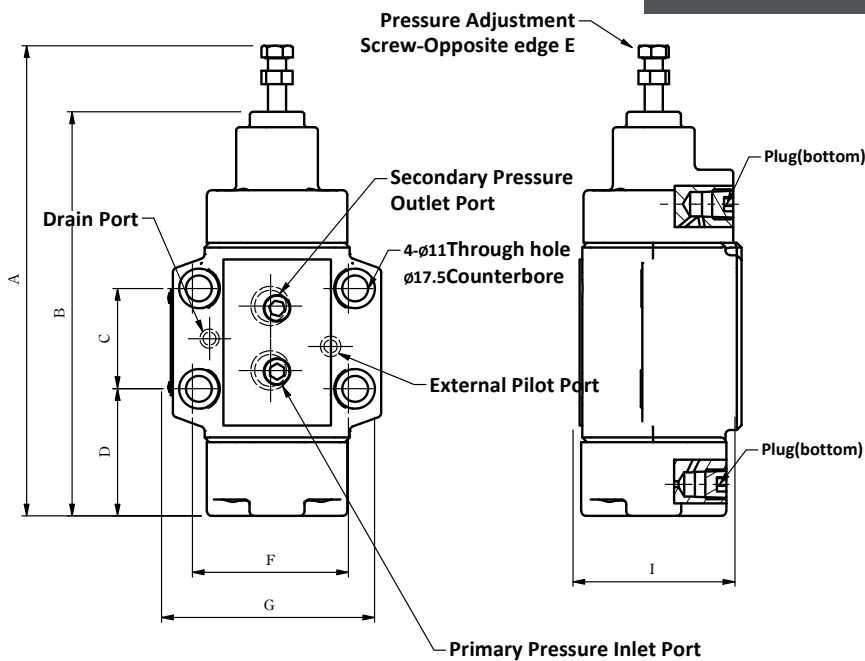

Model	A	B	C	D	E	F	G	H	I
UG-03	202	172	42.9	51.5	12	66.7	91	42	68
UG-06	230	196	60.3	52.5	14	79.4	100	43	81



Pressure Control Valves
Multi-Functional Pressure Control Valves

Dimensions

UG-10

ISO 5781-AJ-10-2-A

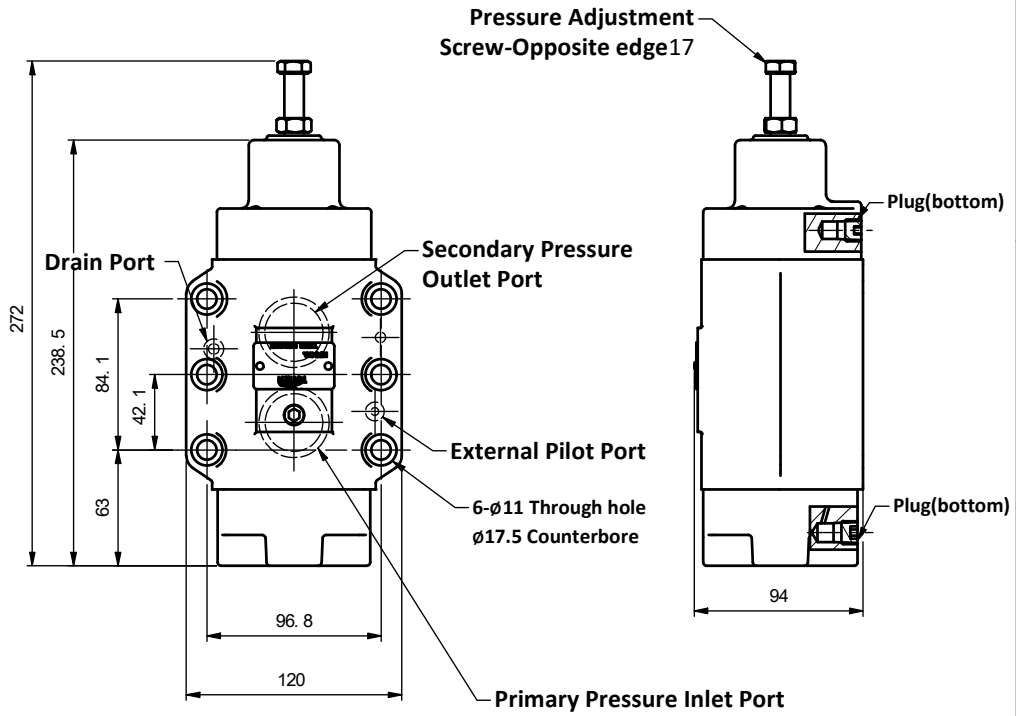

Pressure Control Valves
Multi-Functional Pressure Control Valves

UCG-03/06

UCG-03 : ISO 5781-AG-06-2-A
UCG-06 : ISO 5781-AH-08-2-A

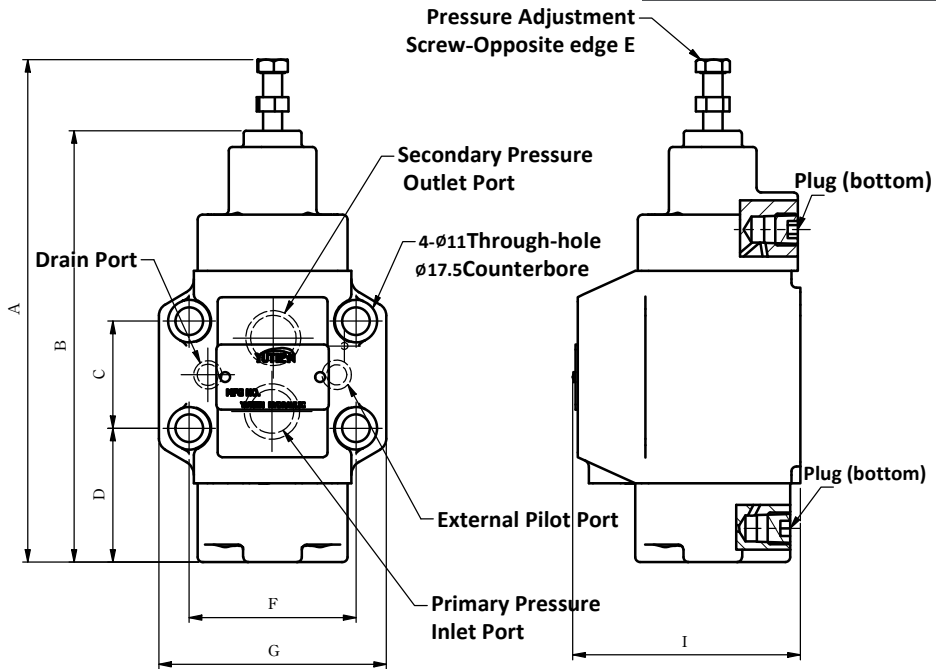

Model	A	B	C	D	E	F	G	H	I
UCG-03	202	172.5	42.9	51.5	12	66.7	90.5	61	91
UCG-06	229	196	60.3	51	14	79.4	102.5	71	110

Dimensions

UCG-10

ISO 5781-AJ-10-2-A

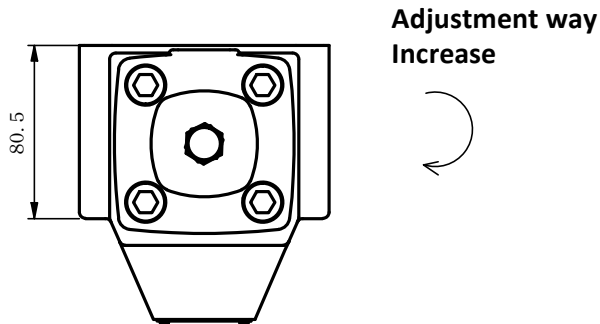

Internal Pilot-Internal Drain

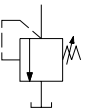
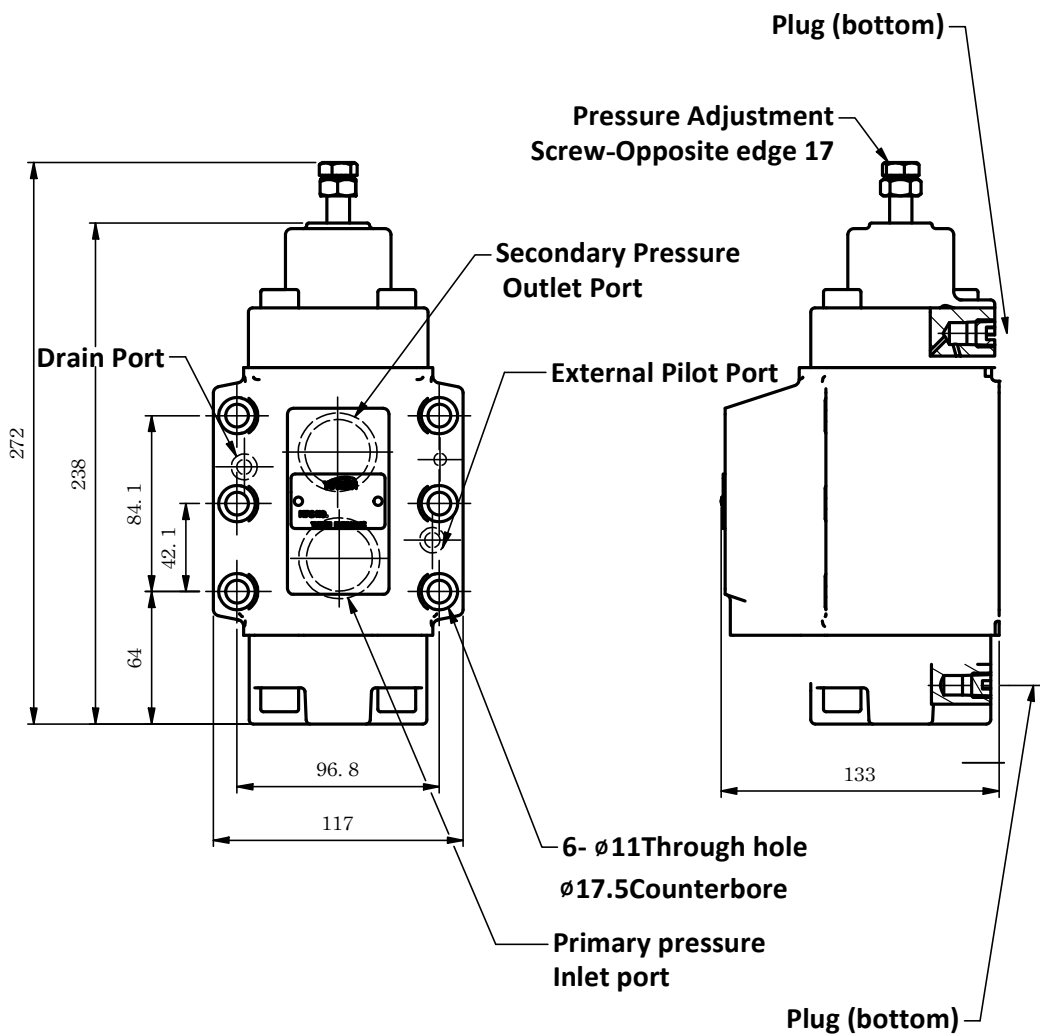

Pressure Control Valves
Multi-Functional Pressure Control Valves

Pressure Reducing Valves



JIS-Graphic Symbol

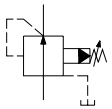
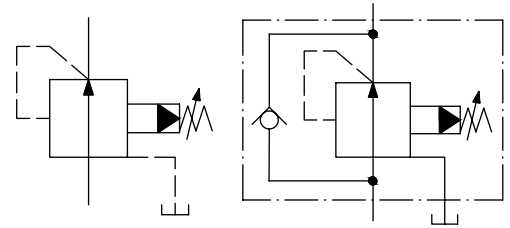

Feature

- The pressure reducing valve is the second circuit, which is used to set the pressure lower than the main circuit and can also be remotely controlled through the remote-control port.
- Pressure reducing check valve is a pressure reducing valve connected in parallel with a check valve, which can reduce pressure in one-direction.

Model Description

PR	C	G	-03	-3
Model /Series	Check Function	Installation Type	Thread Code Size (Inch)	Pressure Adjustment Range Kg/cm ²
Pressure Reducing Valves	None: Not Required C: Check Valve	G: Sub-Plate Mounting	03:3/8"	1:5-70
		T: Threaded Connection	06:3/4"	2:35-140
			10:1 1/4"	3:70-210

Specification

Model /Type	Operating Pressure (Max.) Kg/cm ²	Rated Flow (Max.) L/min	Drain Flow Lpm
PR**-03	210	60	0.8
PR**-06		120	1.0
PR**-10		240	1.2

Instructions

- **Pressure Adjustment:** When adjusting the pressure, loosen the lock nut, turn the handle slowly, clockwise is the pressure increase, counterclockwise is the pressure decrease, please don't forget to tighten the fixing nut after the adjustment.
- **Drain port connection:** The pressure of the drain port must be kept at a low back pressure close to atmospheric pressure, so the drain port should be directly connected to the tank. There are two pressure ports, which are connected in-line, one as an inlet and the other as an outlet, and the valve can be used with one pressure port plugged.

Dimensions

PRG-03/06

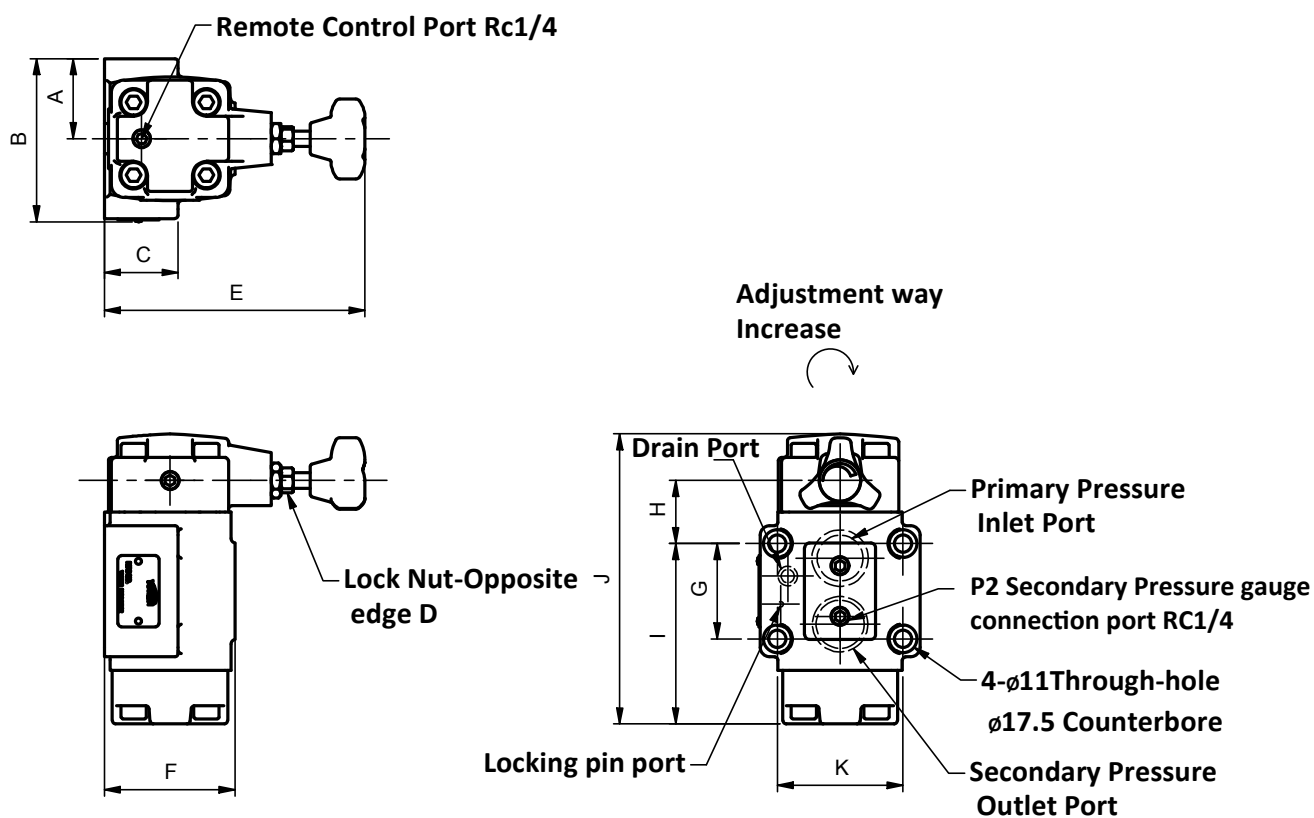

Pressure Control Valves
 Pressure Reducing Valves

Model	A	B	C	D	E	F	G	H	I	J	K
PRG-03	45	90	41	14	170	68	42.9	41	96.5	161	66.7
PRG-06	50	100	43	14	172	81	60.3	38.5	114.5	182	79.4

Dimensions

PRT-03/06

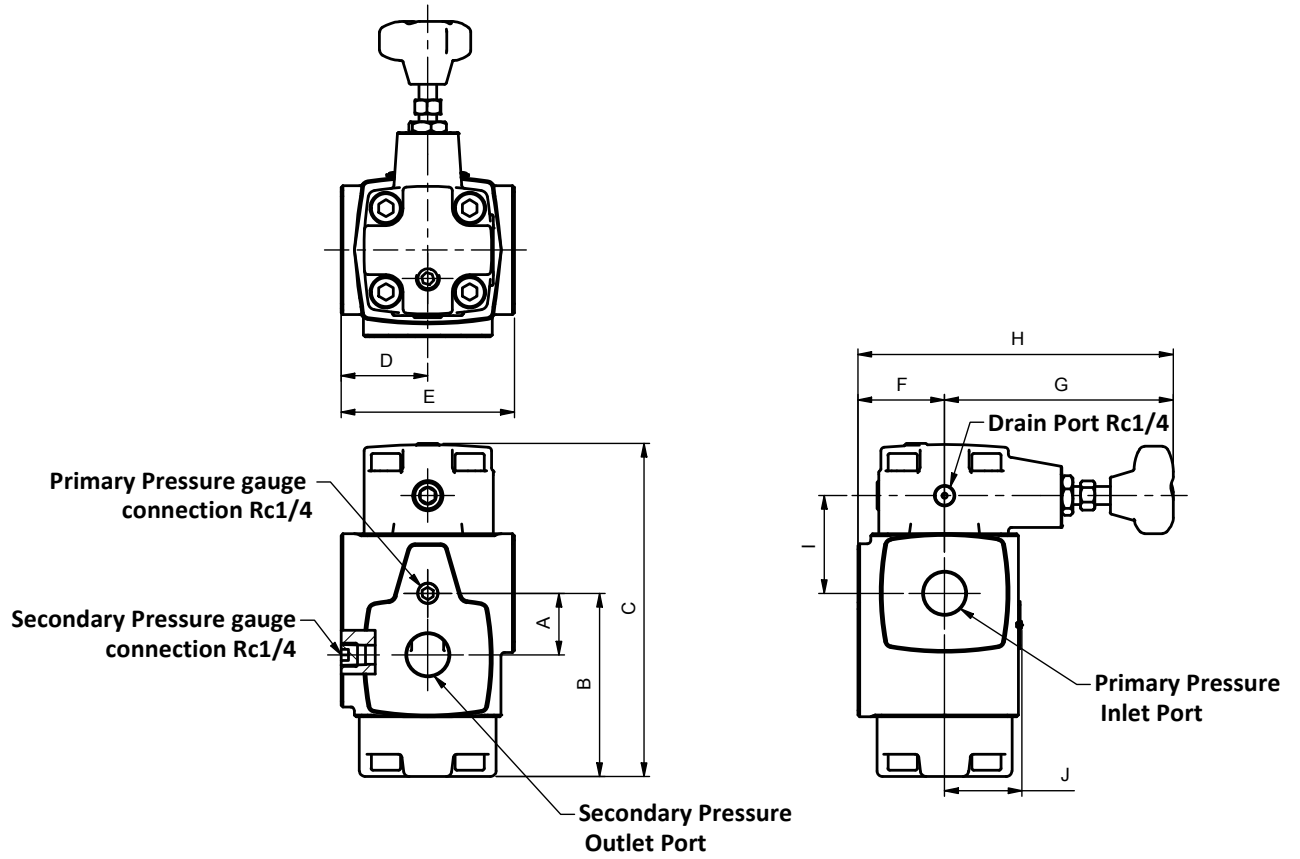

Model	A	B	C	D	E	F	G	H	I	J
PRT-03	28	88.5	160	41	82	42	131	173	50	35
PRT-06	35	100	181.5	47.5	95	51.5	177.5	229	54	41

Dimensions

PRCG-03/06

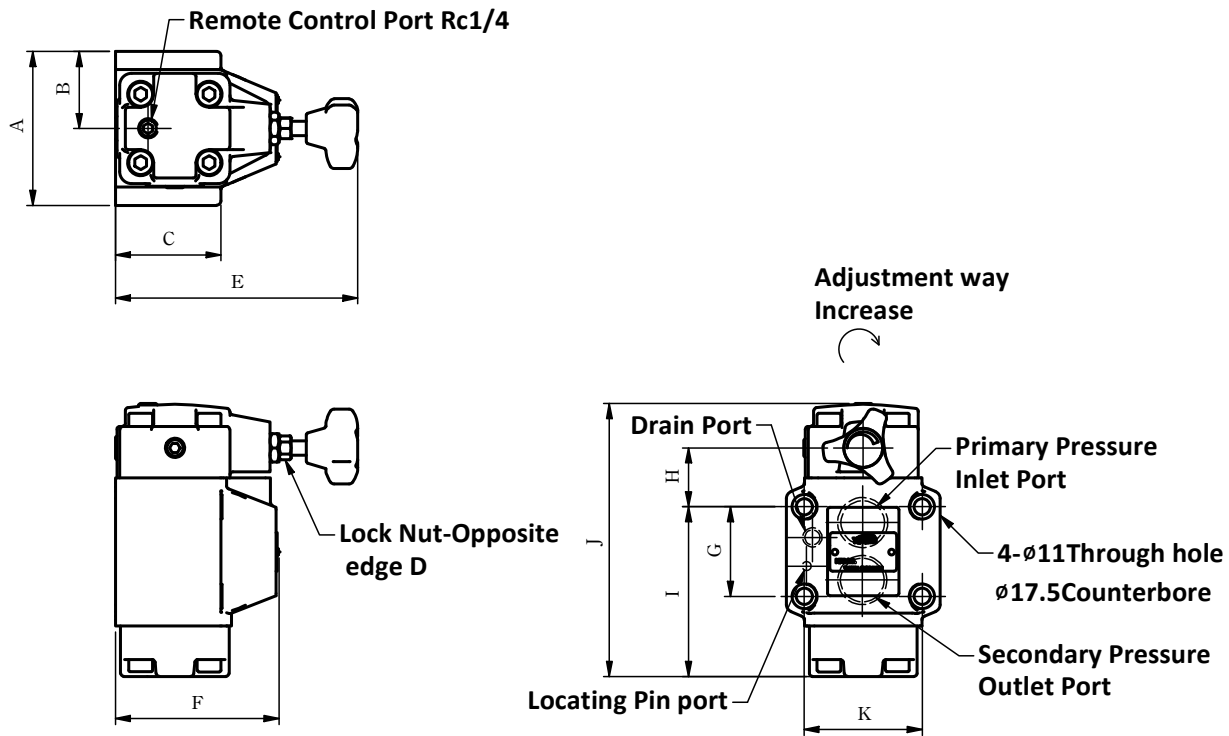

Model	A	B	C	D	E	F	G	H	I	J	K
PRCG-03	91	45.5	61	14	170	89	42.9	41	96.5	161	66.7
PRCG-06	103	51.5	71	14	172	108	60.3	38.5	114.5	182	19.4

Pressure Control Valves
 Pressure Reducing Valves

Dimensions

PRCT-03/06

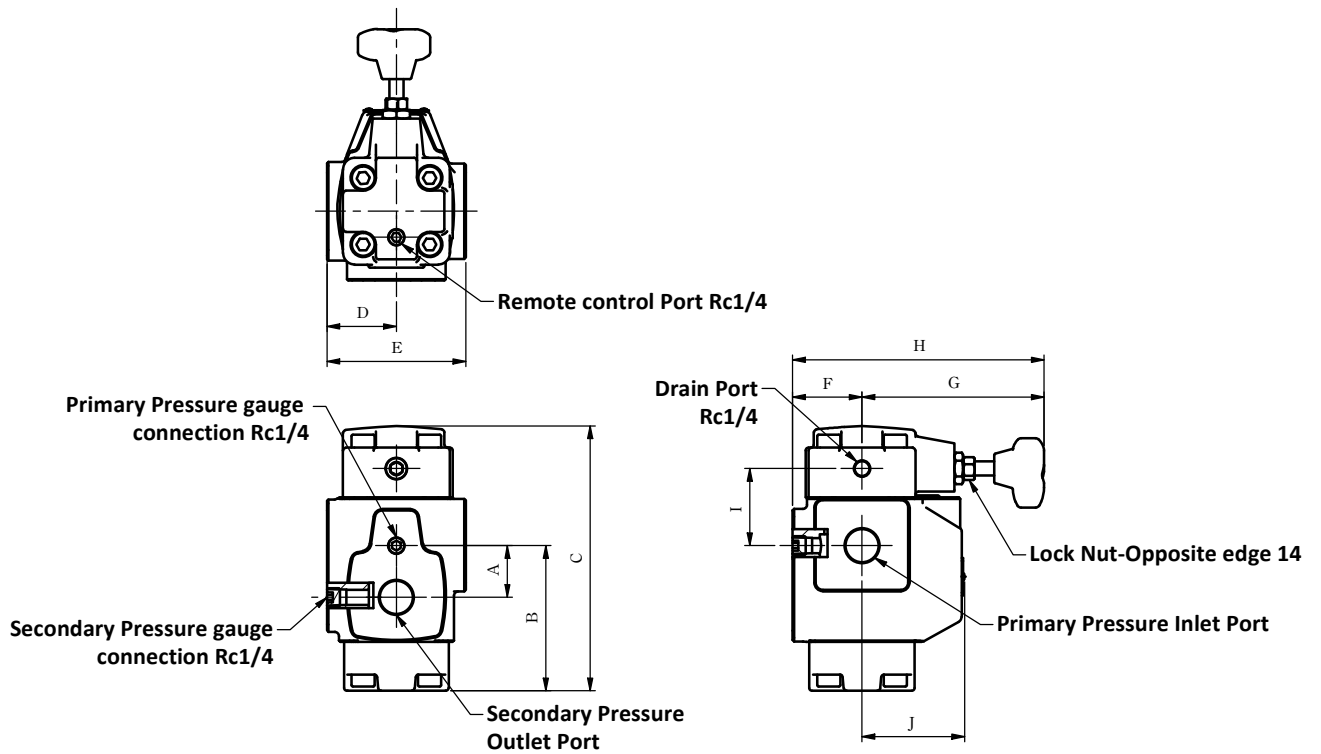

Model	A	B	C	D	E	F	G	H	I	J
PRCT-03	28	88.5	160	39.5	79	42	131	173	50	54
PRCT-06	35	100	181.5	48.5	97	51.5	177.5	229	54	68

B



Pressure Control Valves Pressure Reducing Valves

Counterbalance Valves



JIS-Graphic Symbol

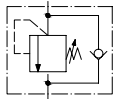
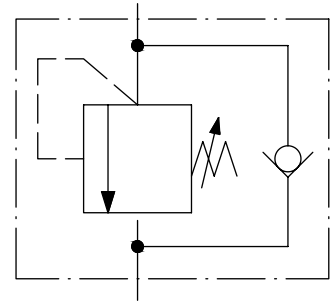

Feature

- URG series counterbalance valve is based on the research and improvement of the current deep-drawing press, which prevents the self-weight balance from being slow, too noisy, the back

pressure control of the plastic injection machine is not accurate, and excessive pressure losses. Can be used in various hydraulic devices to prevent back pressure such as heavy drop.

Model 說明

UR	G	-03	-3
Model /Series	Installation Type	Thread Code Size (Inch)	Pressure Adjustment Range Kg/cm ²

Counterbalance Valves	G: Sub-Plate Mounting	03 : 3/8"	1 : 7-70
		06 : 3/4"	2 : 35-140
		10 : 1-1/4"	3 : 70-210

Specification

Model / Type	Operating Pressure (Max.) Kg/cm ²	Pressure Adjustment Range Kg/cm ²	Rated Flow (Max.) L/min	Cracking Pressure Kg/cm ²
URG-03	250	1 : 7-70	60	3.5
URG-06		2 : 35-140	125	
URG-10		3 : 70-210	250	

Note: Maximum Flow rates are approximation when the valve is fully loaded, the oil specific gravity of 0.85, an operating viscosity of 20 cSt, and the Maximum pressure drop of 30 kgf/cm² at input /output ports.

Instructions

- **Pressure Adjustment:** When adjusting the pressure, loosen the lock nut, turn the handle slowly, clockwise is the pressure increase, counterclockwise is the pressure decrease, please don't forget to tighten the fixing nut after the adjustment.
- **Oil return method:** The oil return pipe should not connect with other valves but should be directly connected to the tank. If it is used to control the pressure of the remote-control valve, the internal volume of the oil pipes is too large, buffeting is likely to occur. Therefore, the length and diameter of the piping should be minimized.

Dimensions

URG-06/10

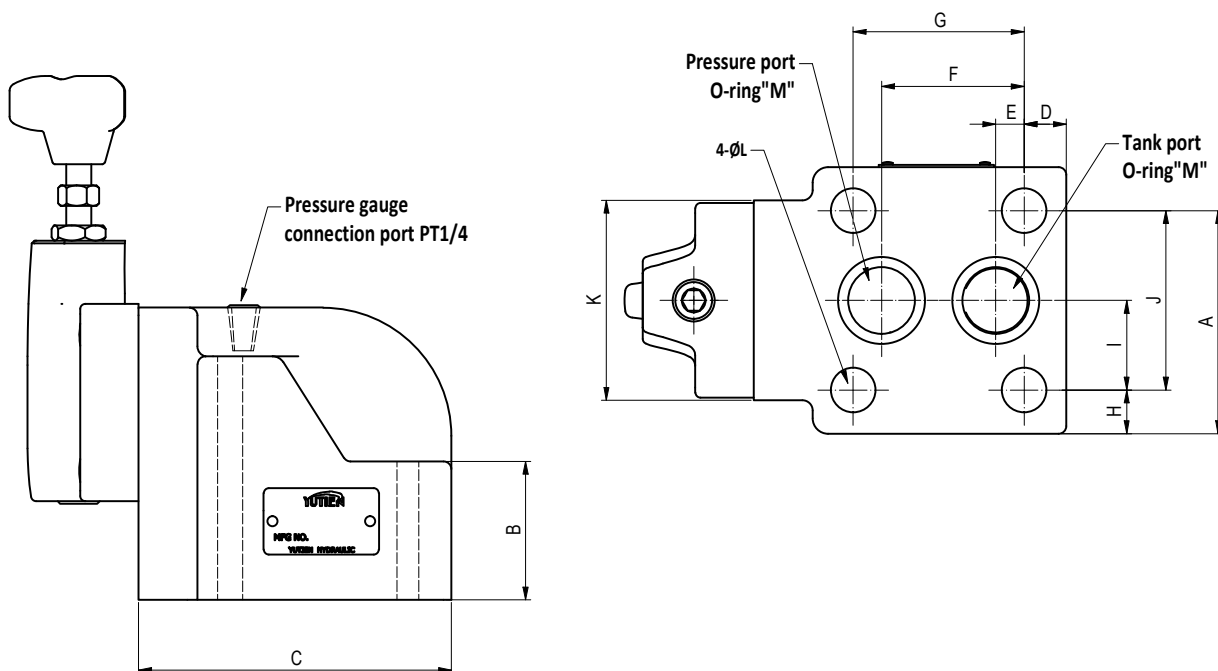

Model	A	B	C	D	E	F	G	H	I	J	K	L	M
URG-06	104	62	133	15	11.4	55.5	66.6	17	35	70	62	17.5	P30
URG-10	125	75	162	19.5	12.6	76.2	88.9	21	41	82	76	22	P40

B

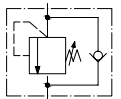



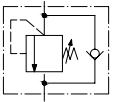



Pressure Control Valves
Counterbalance Valves

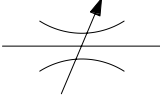

Pressure Control Valves
Counterbalance Valves

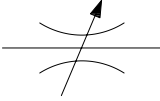
C

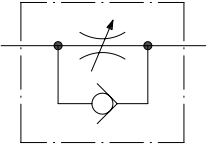
Flow Control Valves

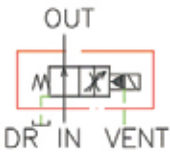
ITEM PICTURE	JIS GRAPHIC SYMBOL	PRODUCT NAME	PAGE
		Restrictors	2
		In-Line Throttle Valves	10
		Flow Controlled and Check Valves	12
		Solenoid Controlled Pilot Operated Restrictors	16

Restrictors



JIS-Graphic Symbol

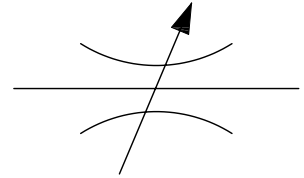

Feature

• The restrictor is used for speed regulation of the actuator in the pressure system and should be constant pressure in the circuit line. As the pressure changes through this valve, it will have

small flow fluctuations.

• With check valve function can control the direction of flow at the same time.

Model Description

TV	C	G	-03
Model /Series	Check Function	Installation Type	Thread Code Size (Inch)
Restrictors	None: Not Required C: Check Valve	T : Threaded Connections G : Sub-Plate Mounting	03 : 3/8" 04 : 1/2" 06 : 3/4" 08 : 1" 10 : 1-1/4"

Note: The rated flow is measured by the pressure drop of 3kg/cm² at the outlet port.

Specification

	Model		Operating Pressure (Max.) Kgf/cm ²	Rated Flow (Max.) L/min
	Throttle	Throttle with Check Valve		
T: Threaded Connections	TVT-03	TVCT-03	250	30
	TVT-04	TVCT-04		50
	TVT-06	TVCT-06		85
	TVT-10	TVCT-10		230
G: Sub-Plate Mounting	TVG-03	TVCG-03	250	30
	TVG-06	TVCG-06		85
	TVG-10	TVCG-10		230

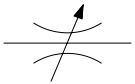

Dimensions

TVT-03/04/06

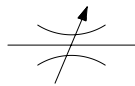
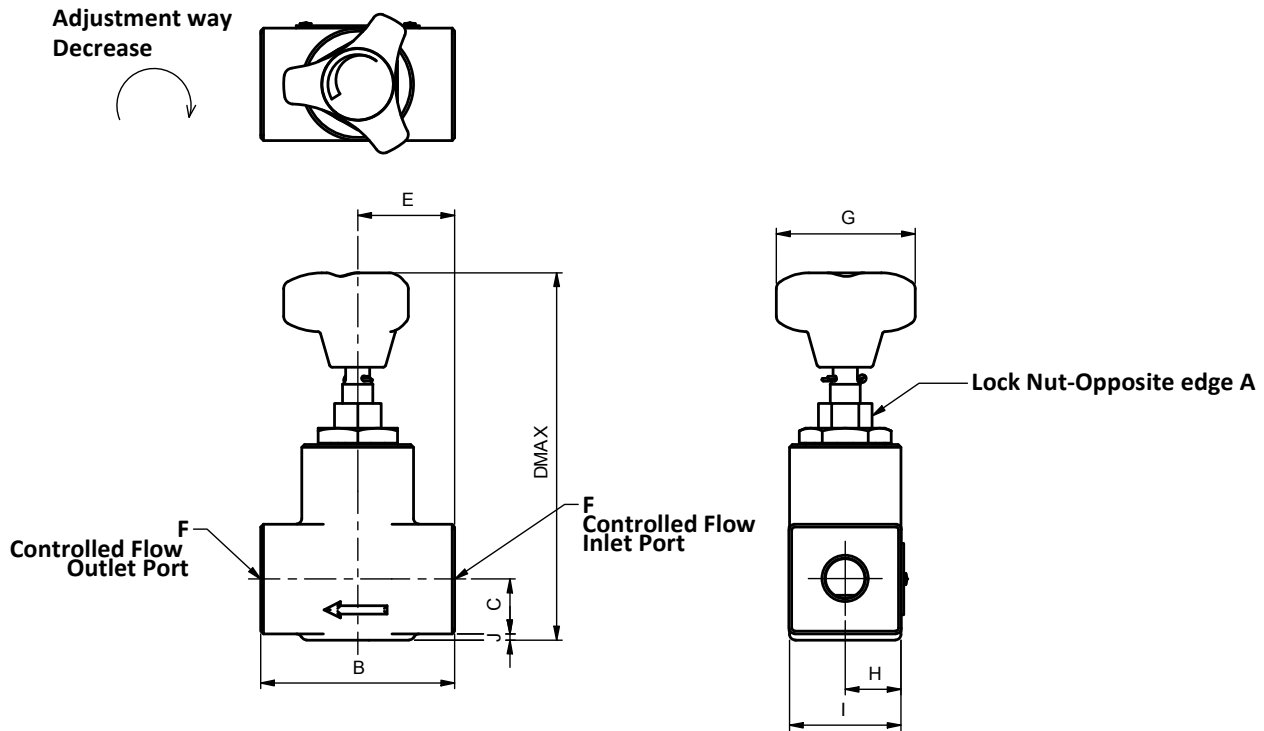

Flow Control Valves
Restrictors

Model	A	B	C	D	E	F	G	H	I	J
TVT-03	17	71	20	142	35.5	RC 3/8	50.5	20.5	41	2.5
TVT-04	17	71	20	142	35.5	RC 1/2	50.5	20.5	41	2.5
TVT-06	19	102	30.5	160	51	RC 3/4	50.5	30.5	61	-

Dimensions

TVG-03/06/10

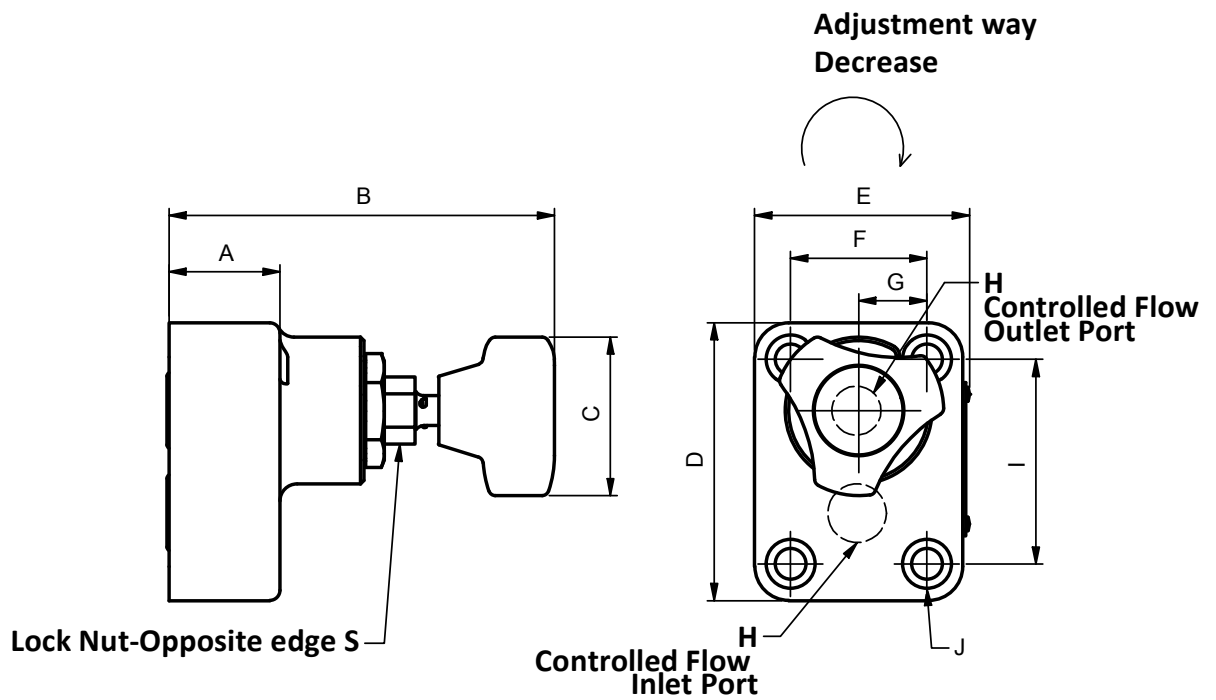

Model	A	B	C	D	E	F	G	H	I	J	S
TVG-03	32.5	127	50.5	80	60.5	40	20	RC 3/8	60	4-Ø14.5 deep, Ø9 through	17
TVG-06	42	140	50.5	96.5	84.5	58	29	RC 3/4	70	4-Ø17 deep, Ø11 through	19
TVG-10	54	160	50.5	121	102.5	72	36	RC 1 1/4	92	4-Ø20.5 deep, Ø14 through	23

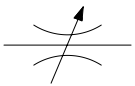

Dimensions

TVCT-03/04/06

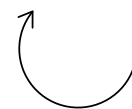
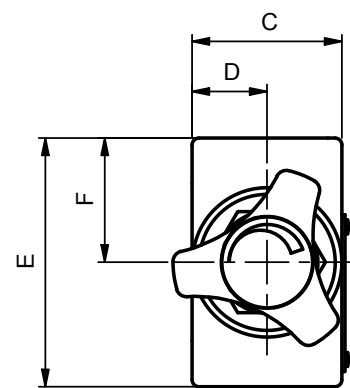
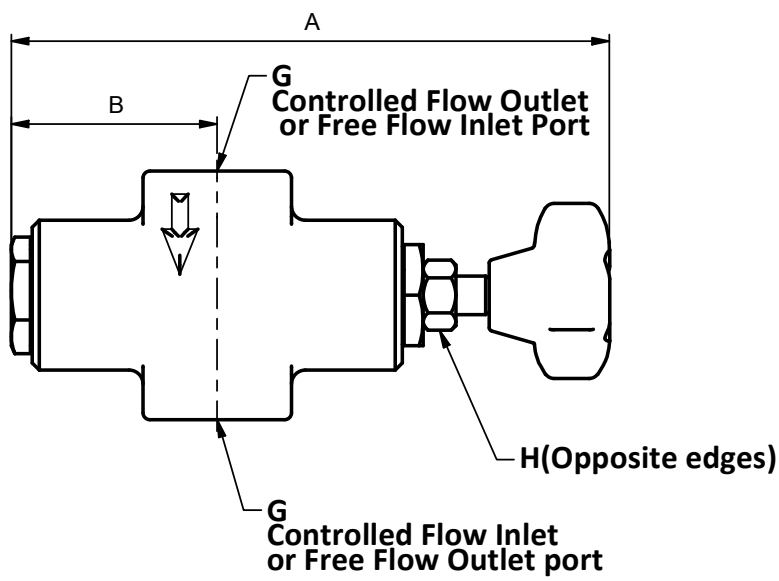

**Adjustment way
Increase**



Flow Control Valves
Restrictors

Model	A	B	C	D	E	F	G	H
TVCT-03	180	59	43	21.5	70	35	RC 3/8	opposite angle 17
TVCT-04	180	59	43	21.5	70	35	RC 1/2	opposite angle 17
TVCT-06	220	67	61	30.5	105	52.5	RC 3/4	opposite angle 19

Dimensions

TVCT-10

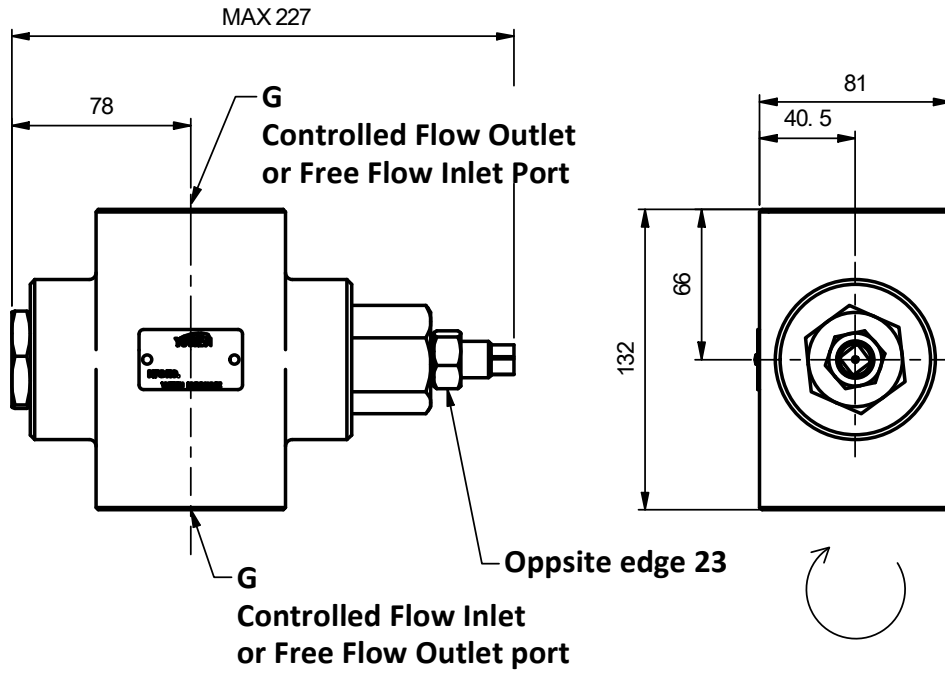

Adjustment way
Increase

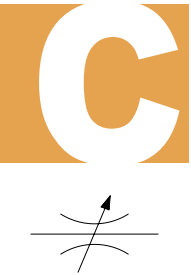
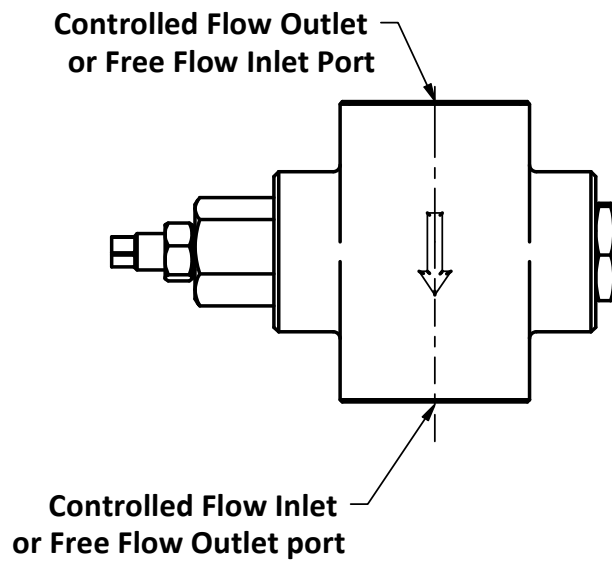

Flow Control Valves
Restrictors

Dimensions

TVCG-03/06

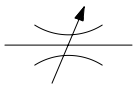
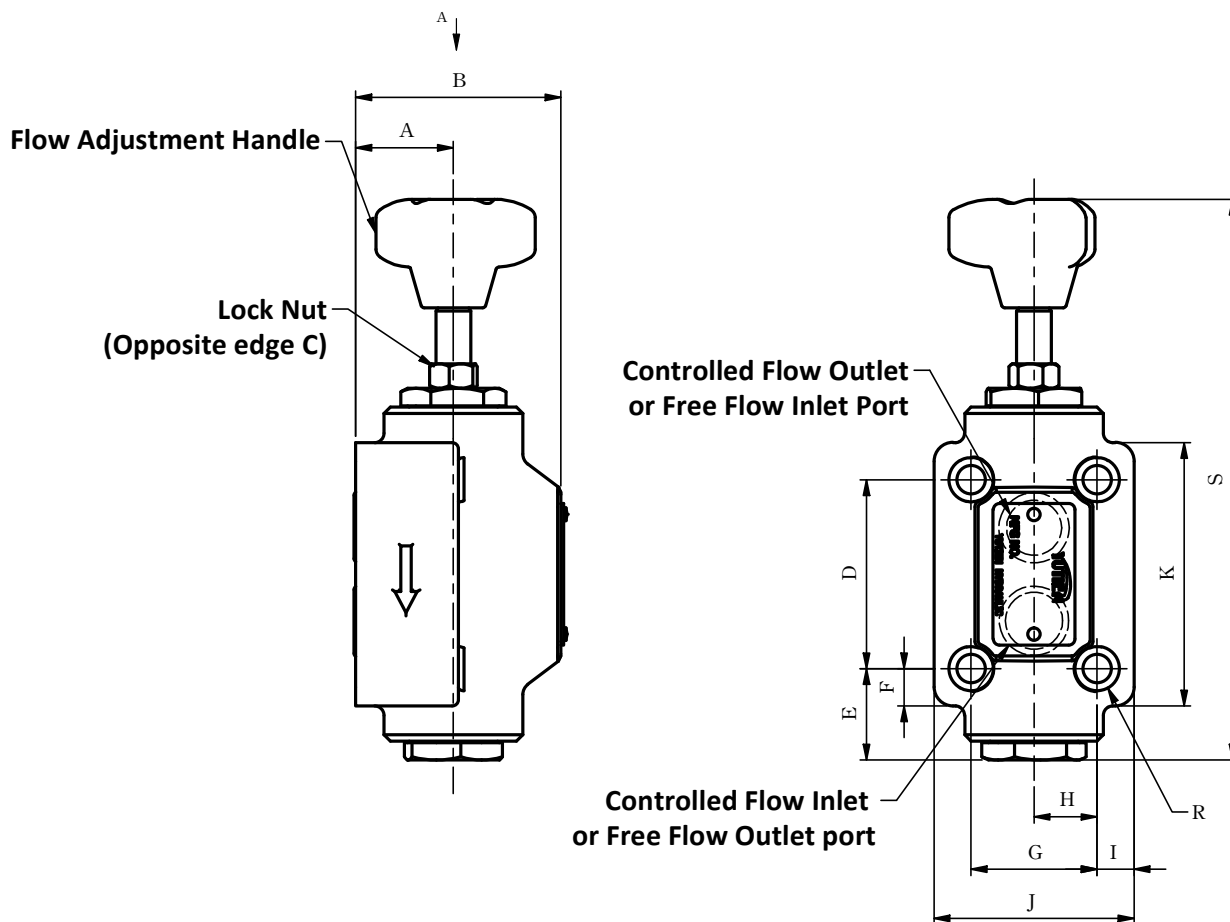

Flow Control Valves
 Restrictors

Model	A	B	C	D	E	F	G
TVCG-03	31.5	65	17	60	29	12	40
TVCG-06	36.5	75	19	70	32	12.5	58

Model	H	J	K	R	S
TVCG-03	20	63	84	Ø14 deep, Ø9 through	178
TVCG-06	29	82	95	Ø17.5 deep, Ø11 through	220

Dimensions

TVCG-10

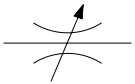
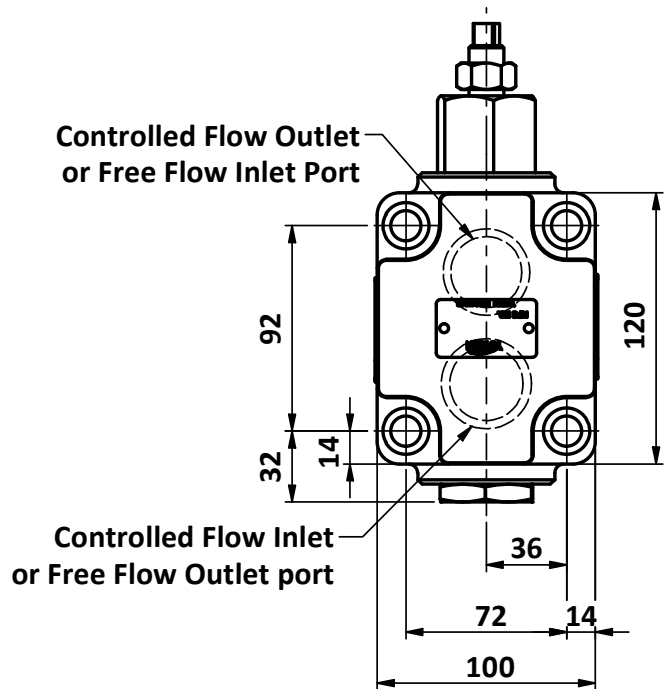
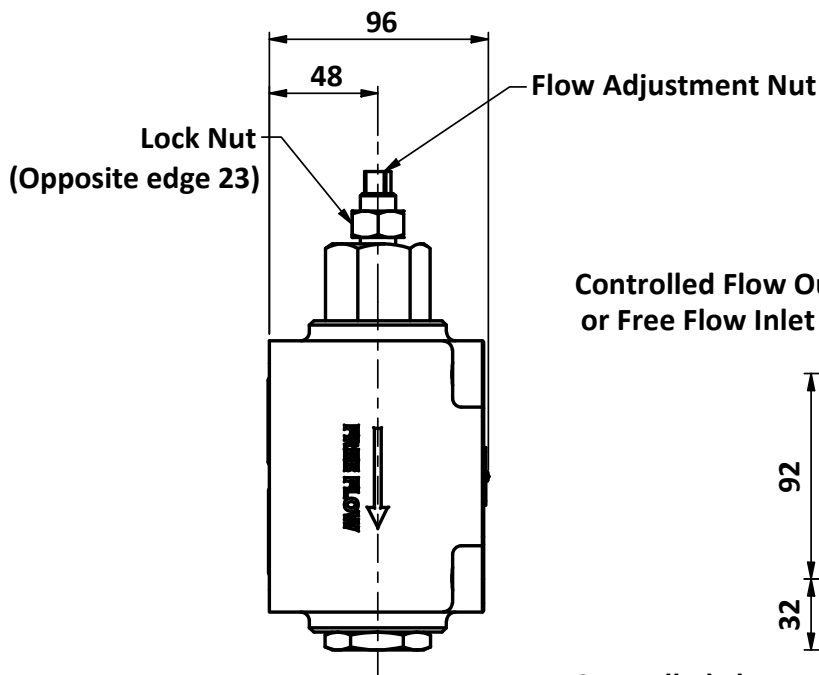
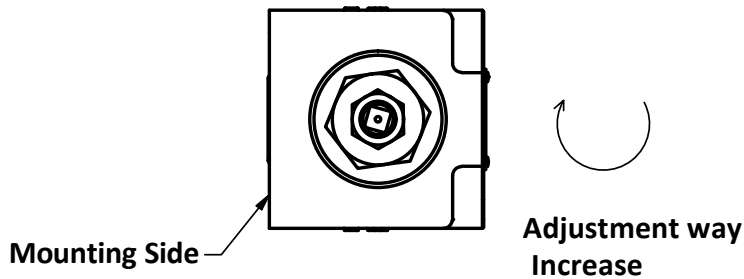

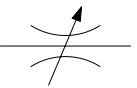

Flow Control Valves
Restrictors

In-Line Throttle Valves



JIS-Graphic Symbol

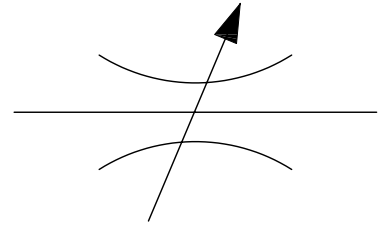

Feature

- The steel working body can withstand pressure up to 210Kg/cm²
- All have been pressure resistance and leak-proof tested, no leakage.
- The internal processing is precise, and the flow regulation speed is linear.

Model Description

TLC	-02
Model /Series	Thread Code Size (Inch)
In-Line	02 : 1/4"
Throttle Valves	03 : 3/8"
	04 : 1/2"
	06 : 3/4"

Specification

Model / Type	Operating Pressure (Max.) Kg/cm ²	Rated Flow (Max.) L/min	Weightkg kg
TLC-02	210	12	0.26
TLC-03		20	0.36
TLC-04		30	0.52
TLC-06		48	0.94

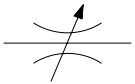

Dimensions

TLC

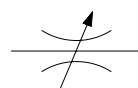
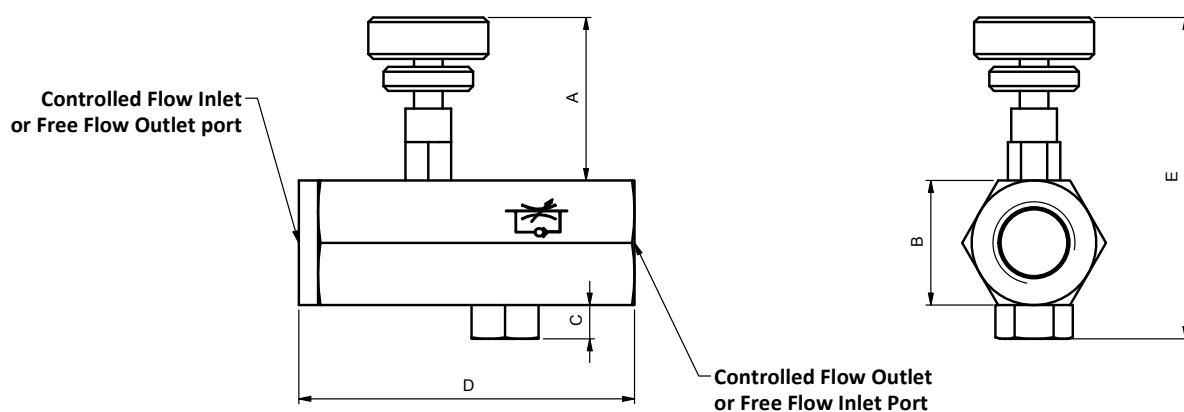

Flow Control Valves
In-Line Throttle Valves

Model	A	B	C	D	E	F	Rated Flow (lpm)	Weight (kg)
TLC-02	40	23	7	62	RC 1/4	12	12	0.26
TLC-03	40	26	7	70	RC 3/8	20	20	0.36
TLC-04	43	32	11	81	RC 1/2	30	30	0.52
TLC-06	46	41	12.5	92	RC 3/4	48	48	0.94

Flow Controlled and Check Valves



JIS-Graphic Symbol

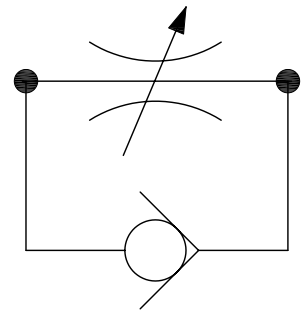

Feature

- The flow control and check valve can adjust the flow in one direction and can flow freely in the reverse direction. There is a clear scale on the nameplate, which can be easily adjusted or reset

the flow rate.

- It is suitable for fast, slow, and fast return of the control system, especially for tool machinery.

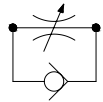

Model Description

FNC	-02
Model /Series	Thread Code Size (Inch)

FNC: Normal Type 02 : 1 / 4"
 FKC: Mechanical Type 03 : 3 / 8"

Specification

Model / Type		Free Flow Rate L/min	Operation Pressure (Max.) Kgf/cm ²	Flow Adjustment Range L/min	Weight kg	
Normal	Mechanical					
FNC-02	FKC-02	20	7	0.01~4	1.12	1.18
FNC-03	FKC-03	30		0.01~8	1.88	1.95

Dimensions

FNC-02

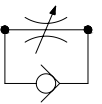
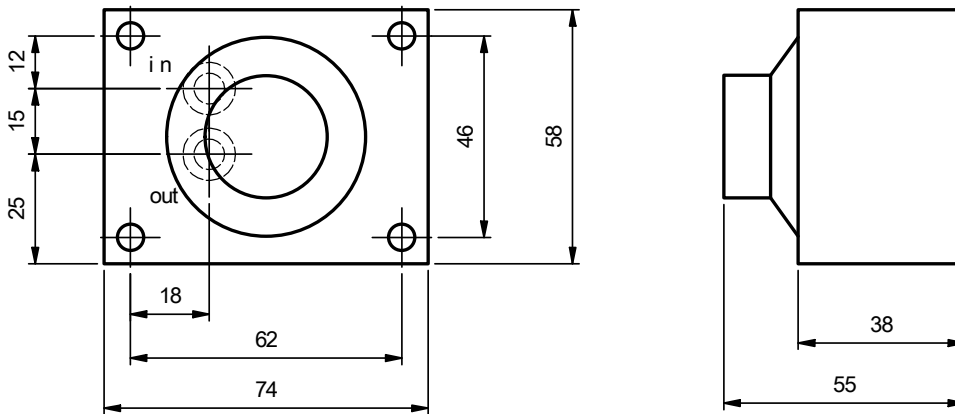

FNC-03

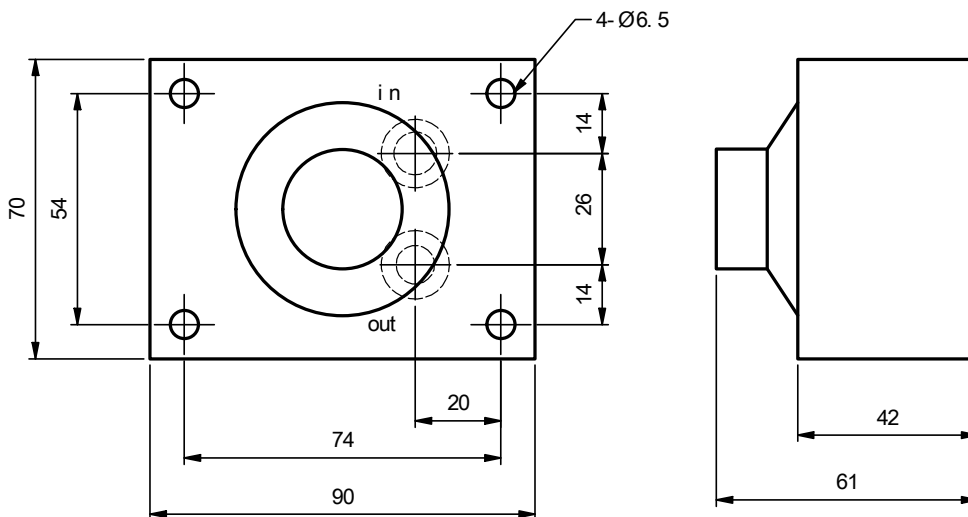

Flow Control Valves
Flow Controlled and Check Valves

Dimensions

FKC-02-A

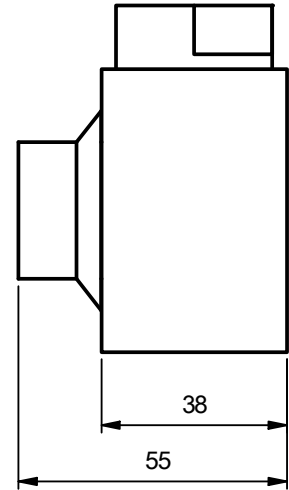
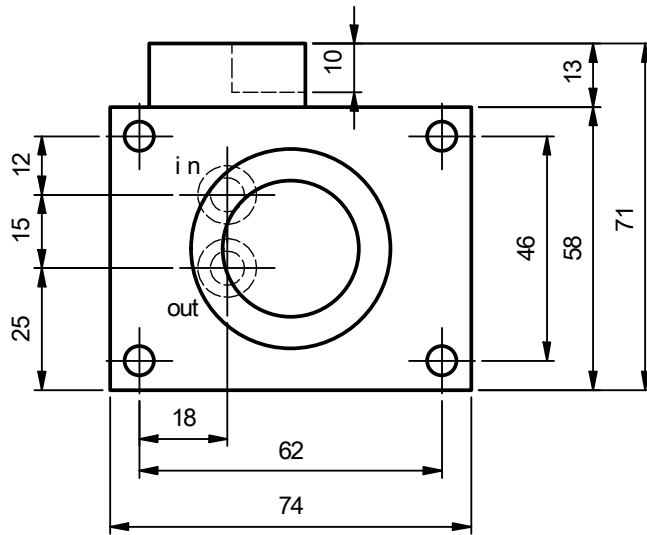

FKC-02-B

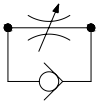
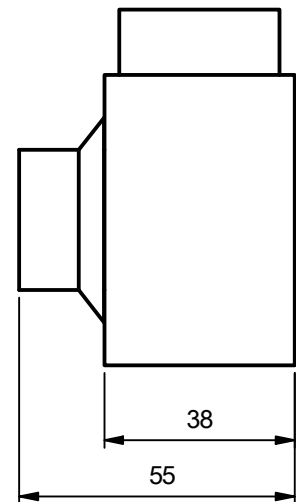
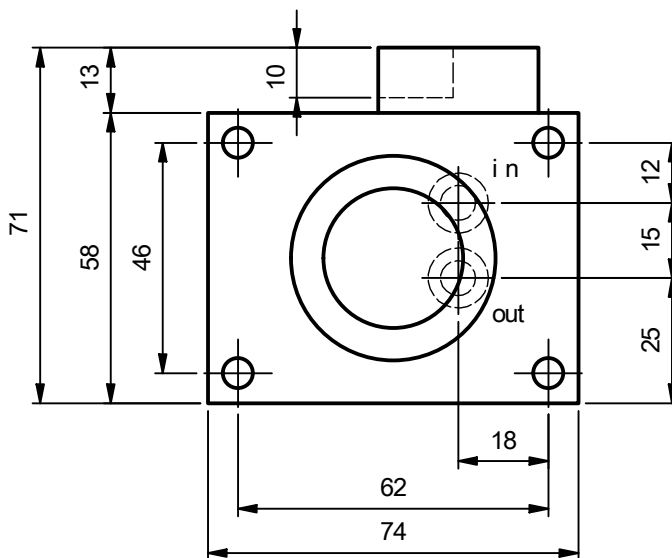

Dimensions

FKC-03-A

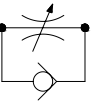
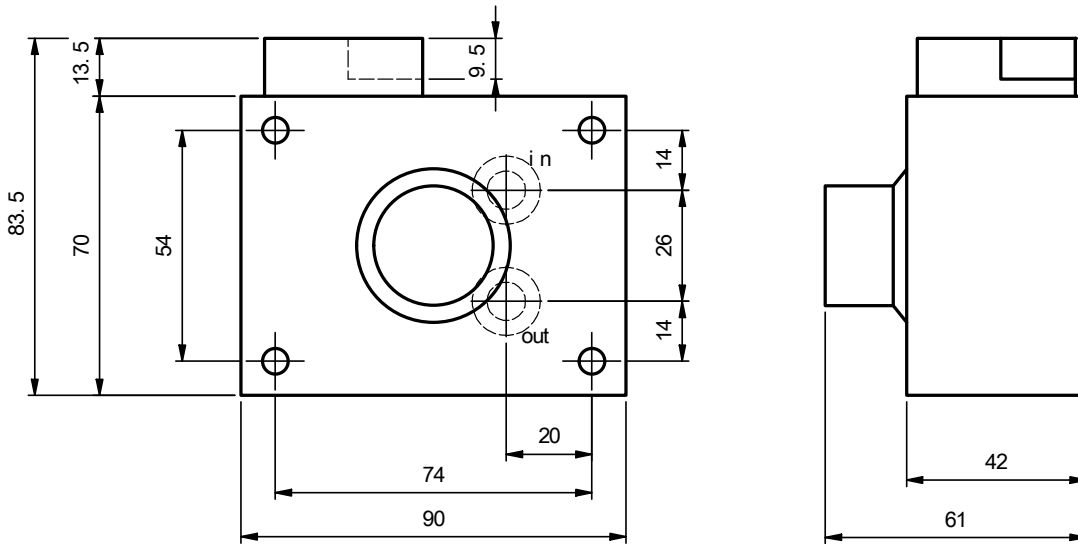

FKC-03-B

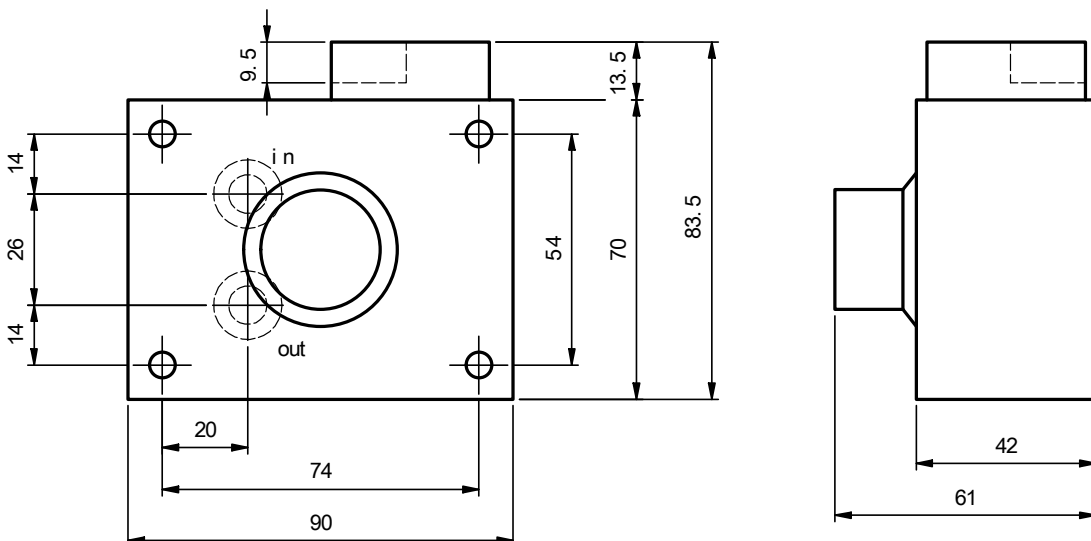

Flow Control Valves
Flow Controlled and Check Valves

Solenoid Controlled Pilot Operated Restrictors



JIS-Graphic Symbol

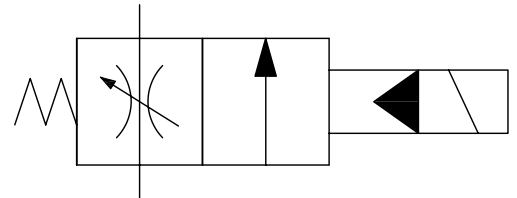

Feature

- Combined with Throttle Valve and Solenoid Directional Valve. There are six types according to the combination and flow adjustment. Commonly used in plastic injection molding and hydraulic machine tools.
- SF series is Two-stage speed control valve, and free flow. While the solenoid is energized, it controls the flow rate. Applied to systems that require Two-stage (Slow/Fast) speed control.
- SDF series is Single-stage speed control valve, and the flow is Normally Closed (NC). While the solenoid is energized, it controls the flow rate. Applied to electrical signal controls the actuator (ON/OFF) and requires speed control.

- SKF type is Three-stage solenoid speed control valve. Applied to systems that require (Slow/ Fast/ Rapid) speed control.
- SFD series is Two-stage solenoid speed control valve. Applied to the systems requires (Slow/ Fast) speed control.
- SD series is Normally Closed (NC), and it is free flow when the solenoid is energized.
- THF series has only throttle function without solenoid directional valve.

Model Description

SF	-06	-A1
Model /Series	Thread Code Size (Inch)	Coil Type (Solenoid Valve) (Optional)
Please refer the series definition table. (p.C17)	03 : 3/8" 06 : 3/4" 10 : 1-1/4"	A1 : AC110V A2 : AC220V A3 : AC380V D1 : DC12V D2 : DC24V

Specification

Model / Type	Thread Code Size (Inch)	Rated Flow (Max.) L/min	Pressure Adjustment Range Kg/cm ²
SF	03	50	210
SDF			
SD	06	120	
SFD			
SKF	10	240	
THF			

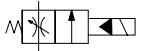

Series Definition Table

Model /Series	With Solenoid Valve DSW Series (Optional)	Speed Stage	Flow Adjustment Handles	JIS Symbol
SF	Single Coil DSW-02-2A2	2	1	
SDF	Single Coil DSW-02-2B2	2	1	
SD	Single Coil DSW-02-2B2	2	0	
SFD	Single Coil DSW-02-2B2	2	2	
SKF	Dual Coil DSW-02-3C4	3	2	
THF	None	1	1	

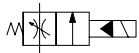

Flow Control Valves
 Solenoid Controlled Pilot Operated Restrictors

Note: Solenoid Directional Valve is for optional purchases.

Dimensions

SF-03

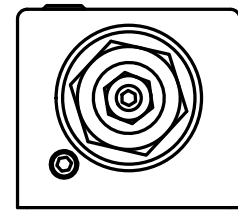
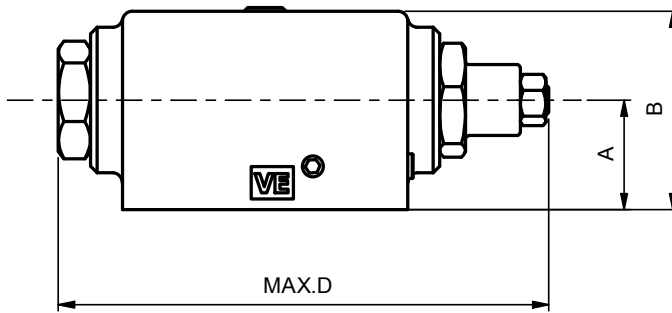
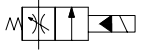
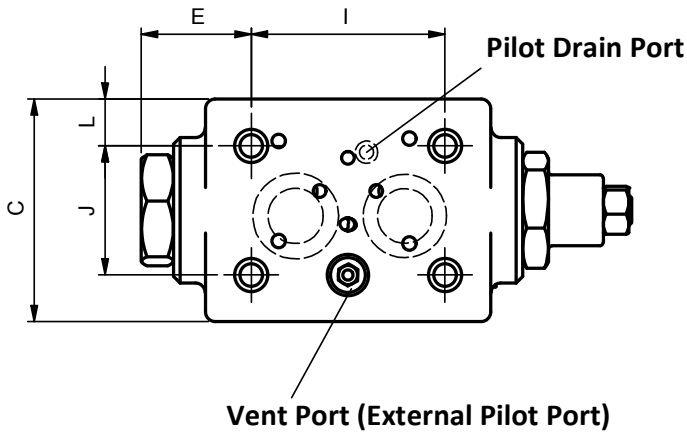

Increase

Model	A	B	C	D	E	I	J	L
SF-03	31	62	68.5	170	33.5	60	40	13.5



Flow Control Valves
Solenoid Controlled Pilot Operated Restrictors

Dimensions

SF-06/10

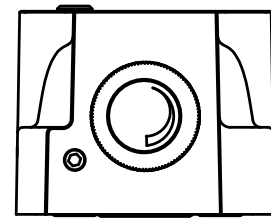
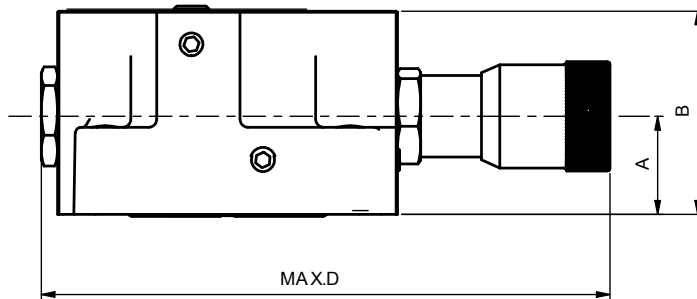
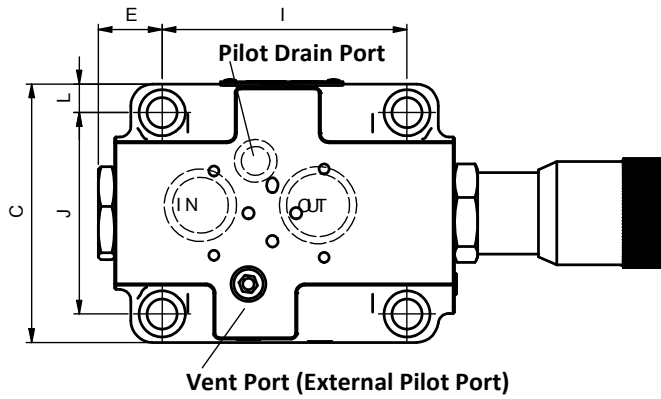

Increase

Model	A	B	C	D	E	I	J	L
SF-06	37.5	75	95	210	23	90	74	10.5
SF-10	42.5	85	110	245	27	112	86	10.5

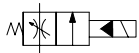

Flow Control Valves
Solenoid Controlled Pilot Operated Restrictors

Dimensions

SDF-03

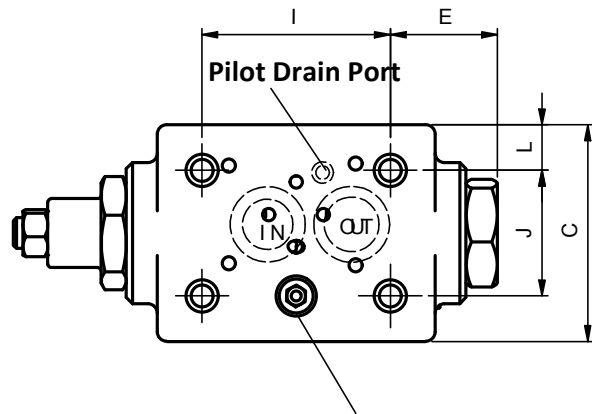

Vent Port (External Pilot Port)

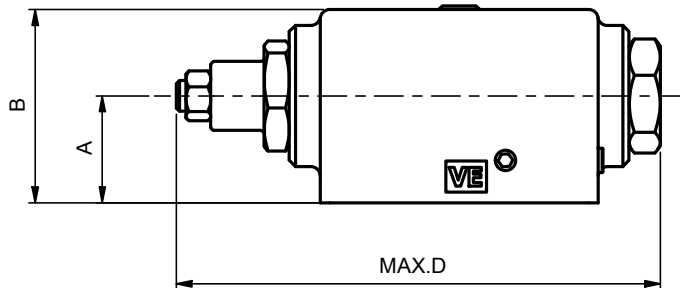
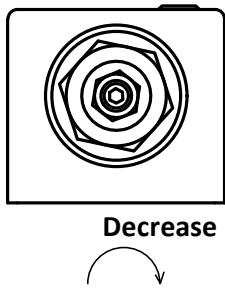

Model	A	B	C	D	E	I	J	L
SDF-03	31	62	68.5	170	33.5	60	40	13.5

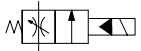

Flow Control Valves
Solenoid Controlled Pilot Operated Restrictors

Dimensions

SDF-06/10

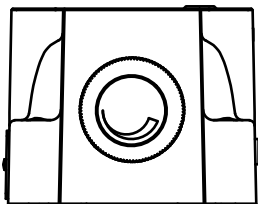
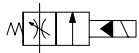
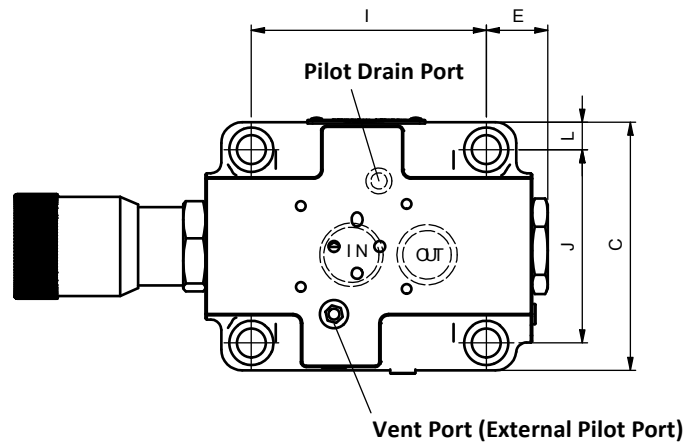

Decrease

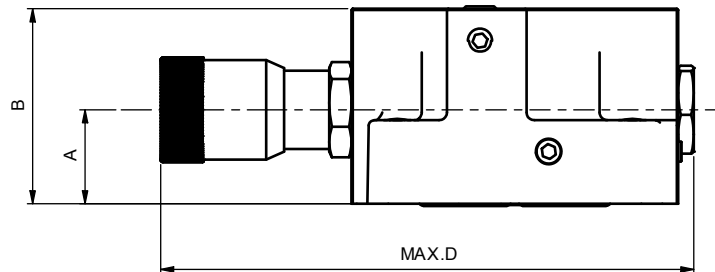

Flow Control Valves
Solenoid Controlled Pilot Operated Restrictors

Model	A	B	C	D	E	I	J	K	L
SDF-06	37.5	75	95	210	23	90	74	31.5	10.5
SDF-10	42.5	85	110	245	27	112	86	37.5	10.5

Dimensions

SD-03

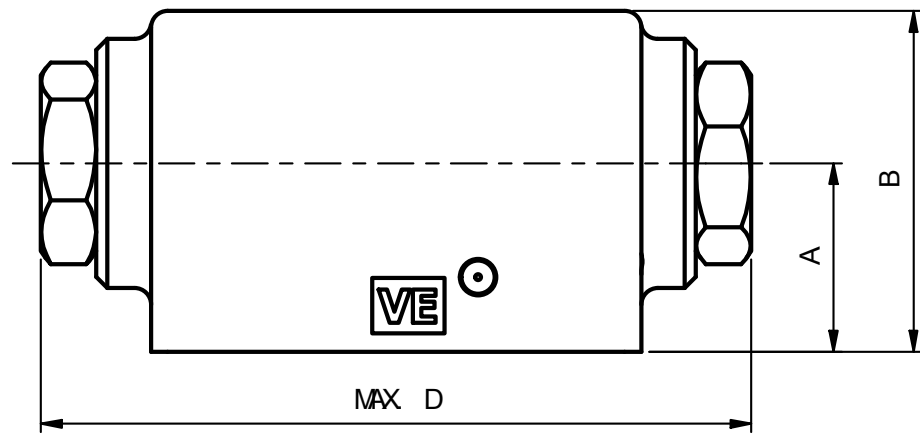
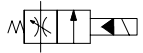
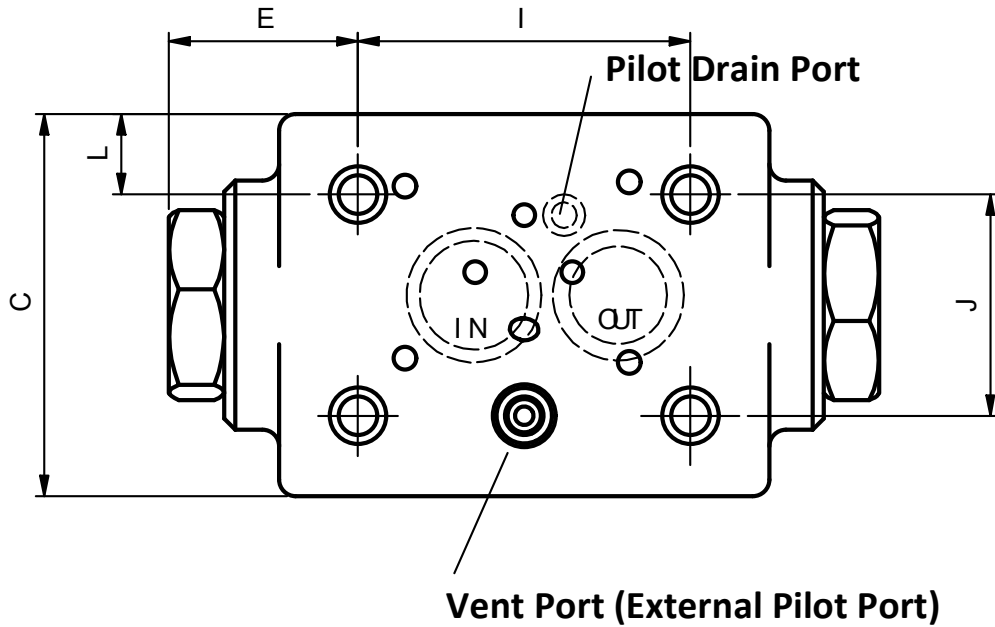

Model	A	B	C	D	E	I	J	L
SD-03	34.5	61.7	68.3	128	33.5	60	40	13.5

Flow Control Valves
Solenoid Controlled Pilot Operated Restrictors

Dimensions

SD-06/10

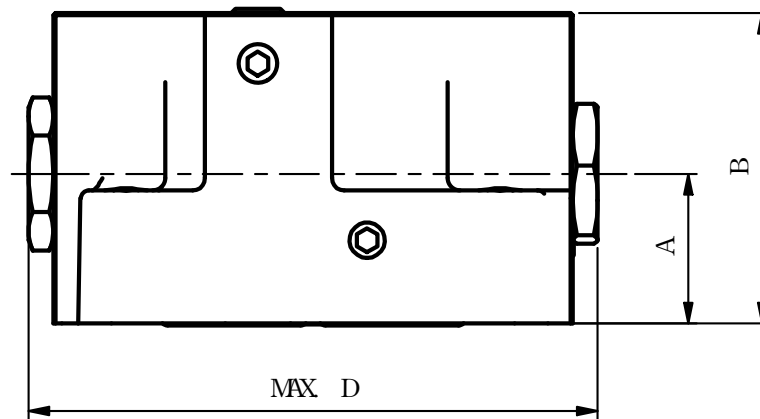
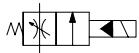
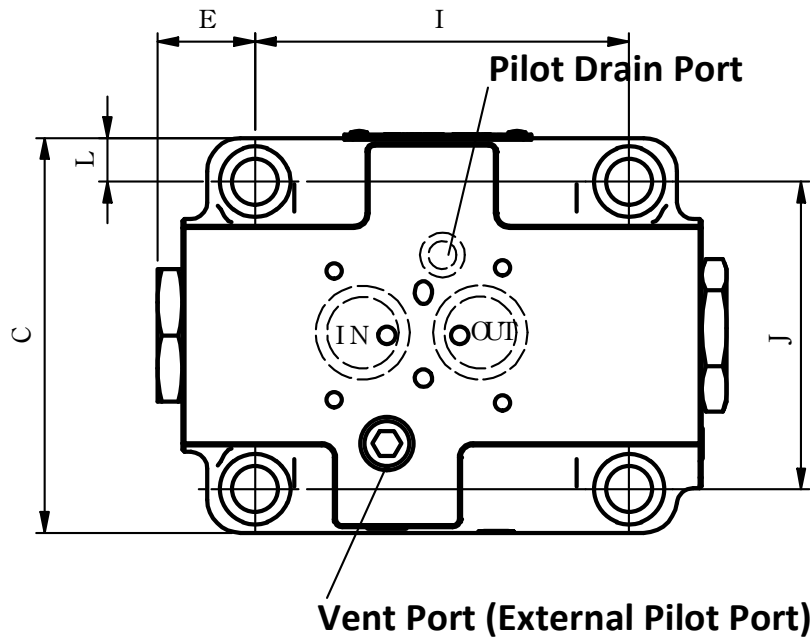

Model	A	B	C	D	E	J	L	I
SD-06	37.5	75	94.5	137.5	23	74	10.5	90
SD-10	42.5	85	110	166	27	86	10.5	112

Flow Control Valves
Solenoid Controlled Pilot Operated Restrictors

Dimensions

SFD-06/10

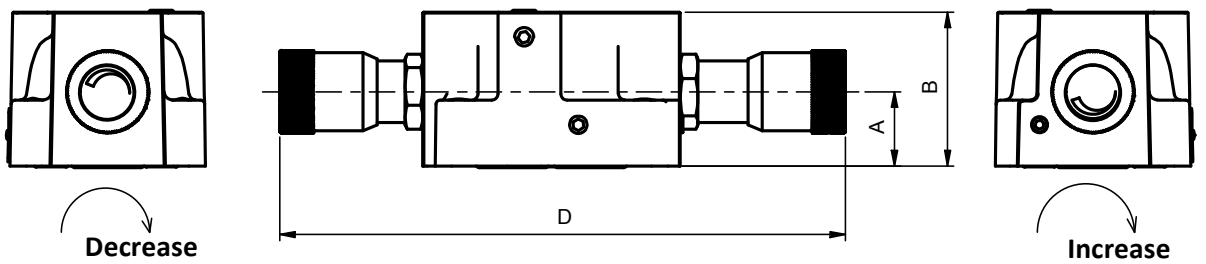
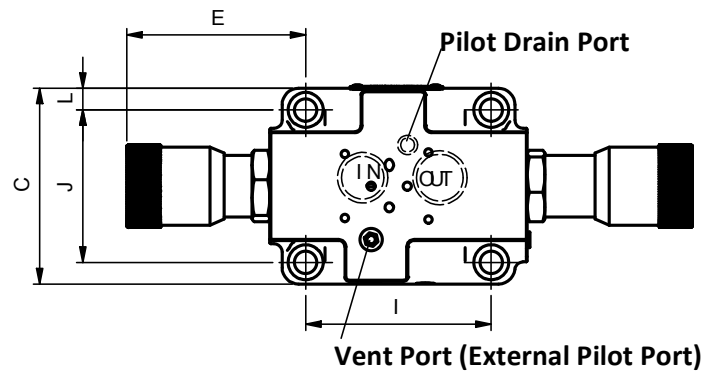

Model	A	B	C	D	E	I	J	L
SFD-06	37.5	75	95	285	98.5	90	74	10.5
SFD-10	42.5	85	110	320	105.5	112	86	10.5

Dimensions

SKF-03

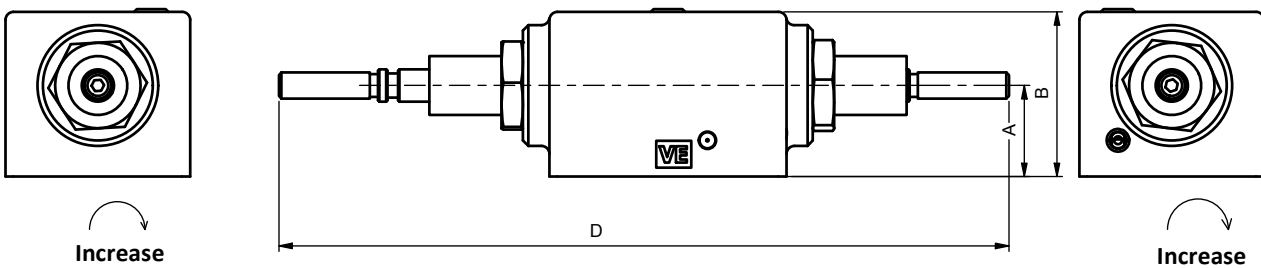
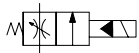
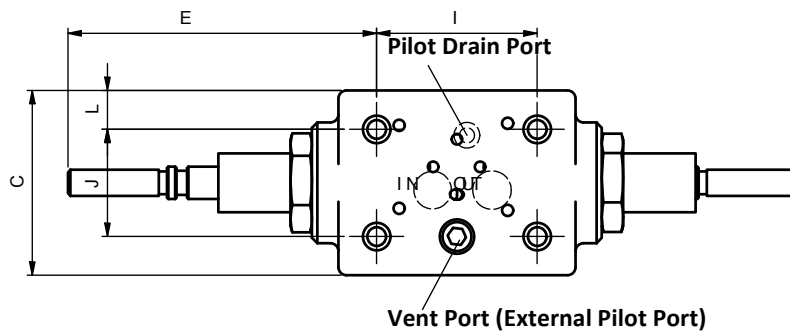

Model	A	B	C	D	E	I	J	L
SKF-03	31	62	68.5	236	88	60	40	13.5

Flow Control Valves
Solenoid Controlled Pilot Operated Restrictors

Dimensions

SKF-06

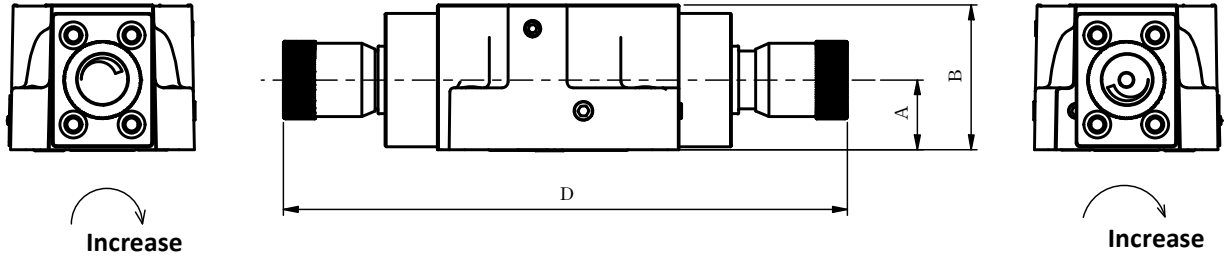
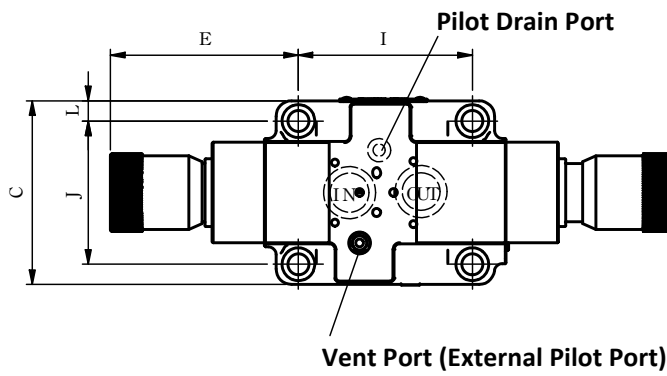

Model	A	B	C	D	E	I	J	L
SKF-06	37.5	75	97	327	118.5	90	74	11.5

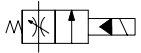

Flow Control Valves
Solenoid Controlled Pilot Operated Restrictors

Dimensions

THF-06

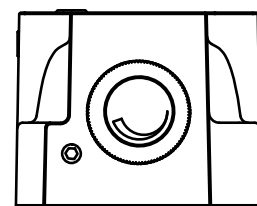
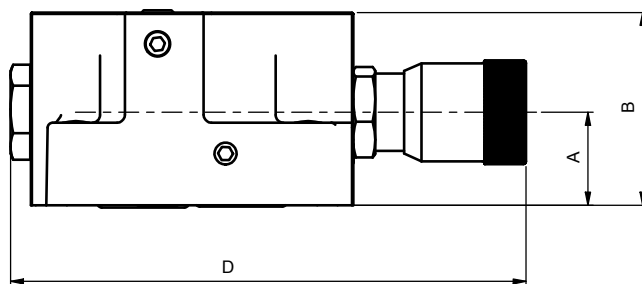
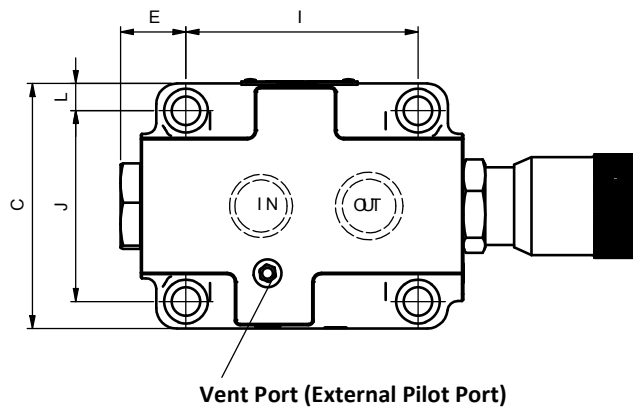

Increase

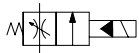

Flow Control Valves
Solenoid Controlled Pilot Operated Restrictors



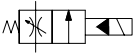







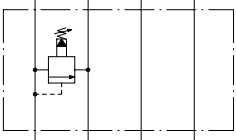

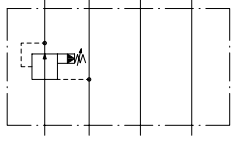
Model	A	B	C	D	E	I	J	K	L
THF-06	37.5	75	95	210	23	90	74	31.5	10.5

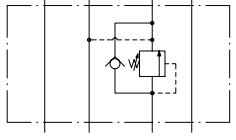

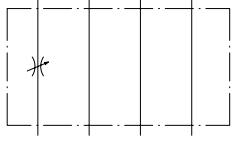
Flow Control Valves
Solenoid Controlled Pilot Operated Restrictors

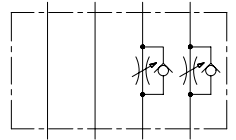
D

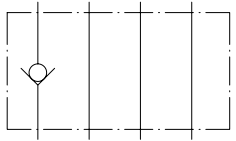
Modular Valves

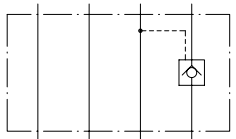
Item Picture	JIS Graphic Symbol	Product Name	Page
		Modular Relief Valves	2
		Modular Reducing Valves	6
		Modular Counterbalance Valves	10
		Modular Throttle Valves	16
		Modular Throttle and Check Valves	20
		Modular Check Valves	28
		Modular Pilot Operated Check Valves	34

Modular Relief Valves



JIS-Graphic Symbol

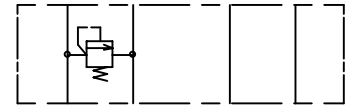

Model Description

SRV	D	-02	P	3
Model /Series	Control Type	Thread Code Size (Inch)	Control Port	Pressure Adjustment Range/ Kg/cm ²
Modular Relief Valves	None: Normal Type D: Remote Control	01 : 1/8" 02 : 1/4" 03 : 3/8" 04 : 1/2" 06 : 3/4"	A: A Port B: B Port P: P Port W: A&B Port	1 : 7-70 2 : 35-140 3 : 140-210

Specification

Model /Type	Operation Pressure (Max.) Kg/cm ²	Rated Flow (Max.) L/min
SRV-02	250	40
SRV-03		80
SRV-04		160
SRV-06		200

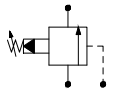

Dimensions

SRV-02A/B/P
ISO 4401-AB-03-4-A

Hydraulic Symbol

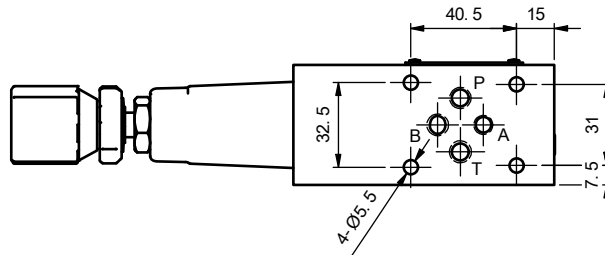
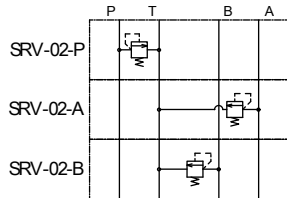

Adjustment way
Increase

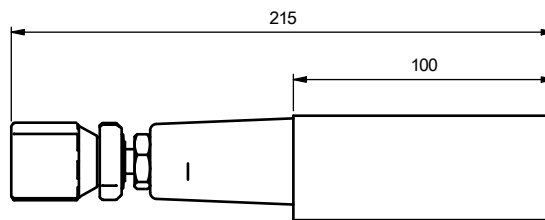
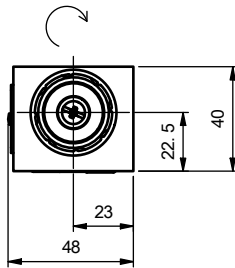

SRV-02W
ISO 4401-AB-03-4-A

Hydraulic Symbol

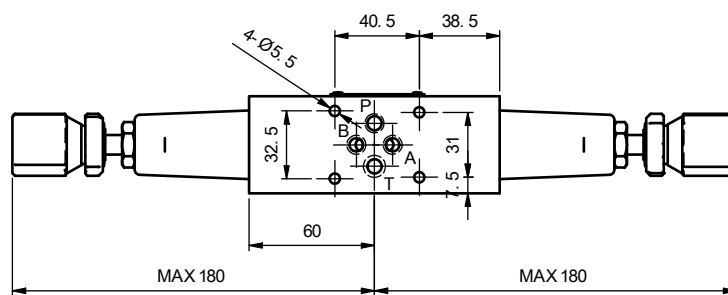

Adjustment way
Increase

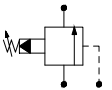
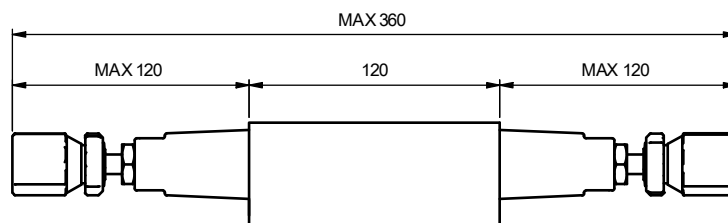
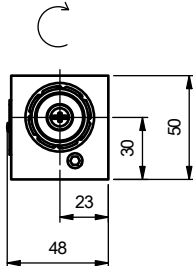

Modular Valves
Modular Relief Valves

Dimensions

SRV-03A/B/P
ISO 4401-AC-05-4-A

Hydraulic Symbol

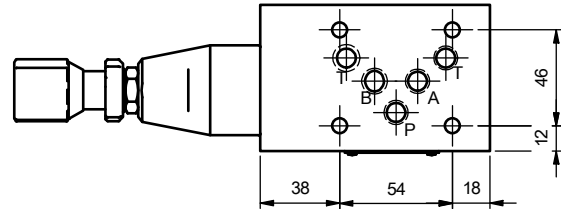
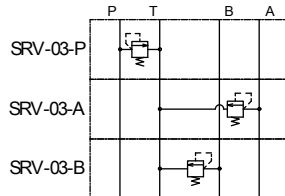

Adjustment way
Increase

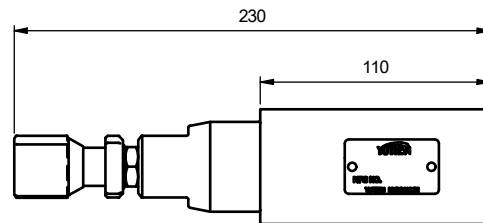
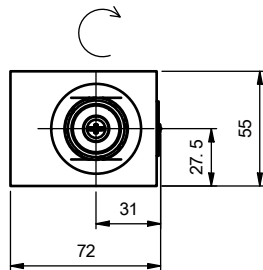

SRV-03W
ISO 4401-AC-05-4-A

Hydraulic Symbol

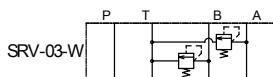

Adjustment way
Increase

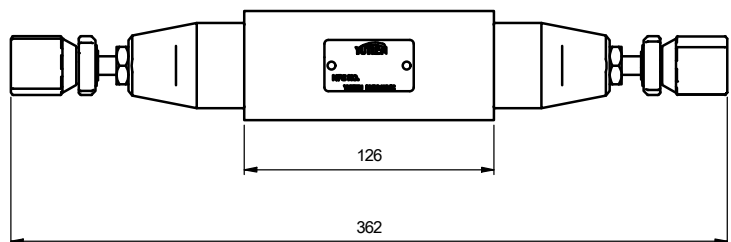
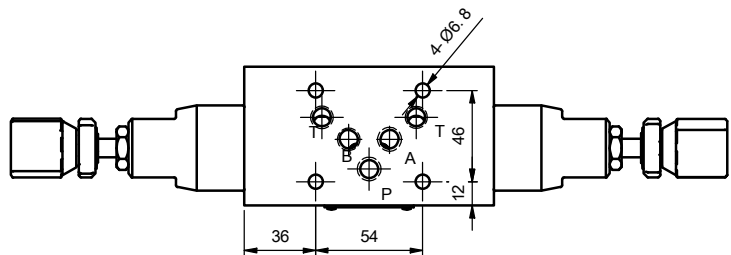
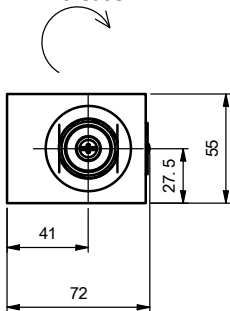

Dimensions

SRV-04
ISO 4401-AD-07-4-A

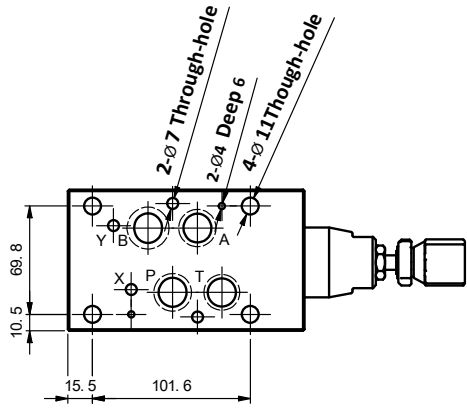

Hydraulic Symbol

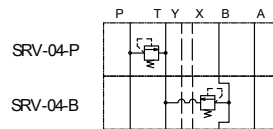

Adjustment way Increase

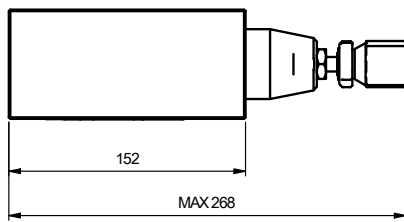
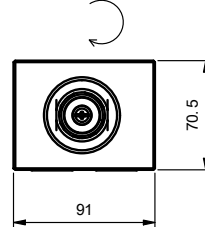

SRV-06
ISO 4401-AE-08-4-A

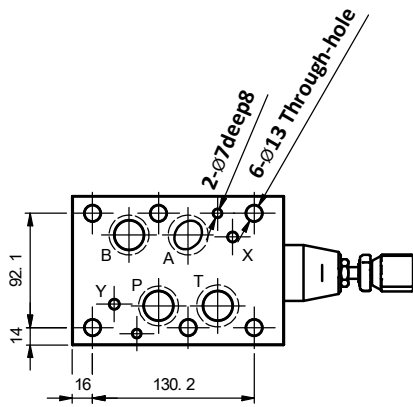

Hydraulic Symbol

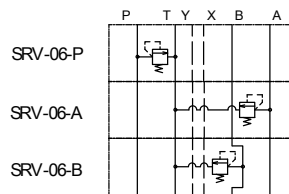

Adjustment way Increase

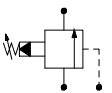
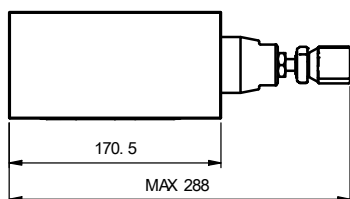
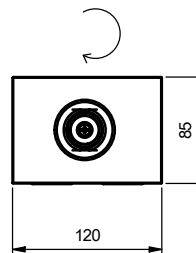

Modular Valves
Modular Relief Valves

Modular Reducing Valves



JIS-Graphic Symbol

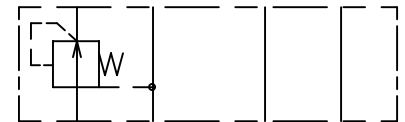

Model Description

Model /Series	Installation Type	Thread Code Size (Inch)	Control Port	Pressure Adjustment Range Kg/cm ²	Design Code
SPR	S	-02	P	3	-20
Modular Reducing Valves	None: Normal Type S: Plate Mounting	02 : 1/4" 03 : 3/8" 04 : 1/2" 06 : 3/4"	A: A Port B: B Port P: P Port	0 : 7 - 35 1 : 7 - 70 2 : 35 - 140 3 : 140 - 210	20: Normal Type 21: Hexagonal Adjusting Type

Specification

Model	Operation Pressure (Max.) Kg/cm ²	Rated Flow (Max.) L/min
SPR-02	250	40
SPR-03		80
SPR-04		160
SPR-06		200

Dimensions

SPR-02A/B/P
ISO 4401-AB-03-4-A

Hydraulic Symbol

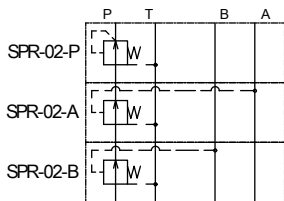

Adjustment way Increase

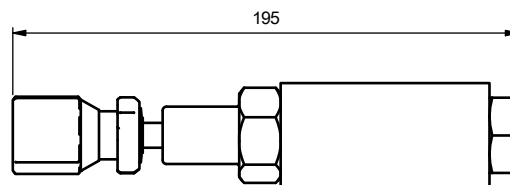
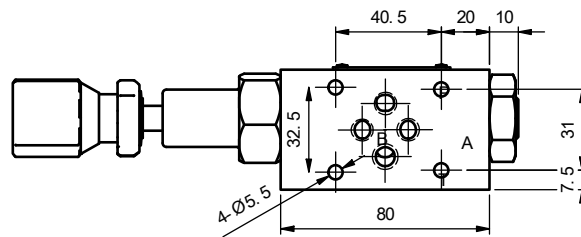
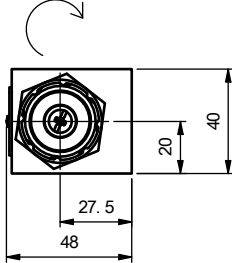

Pressure gauge
connection port RC1/4

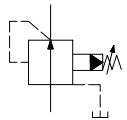

SPR-03A/B/P
ISO 4401-AC-05-4-A

Hydraulic Symbol

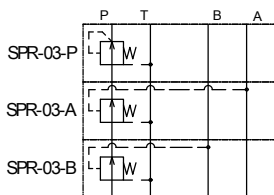

Adjustment way Increase

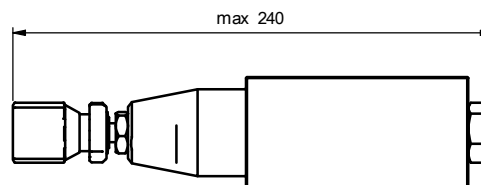
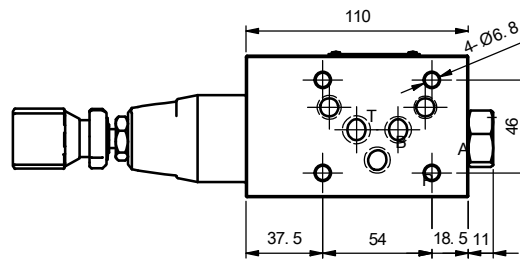
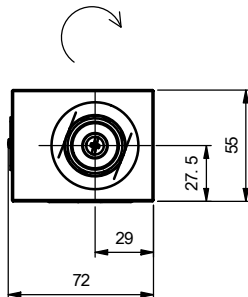

Pressure gauge
connection port RC1/4

Modular Valves
Modular Reducing Valves

Dimensions

SPR-04A/B/P
ISO 4401-AD-07-4-A

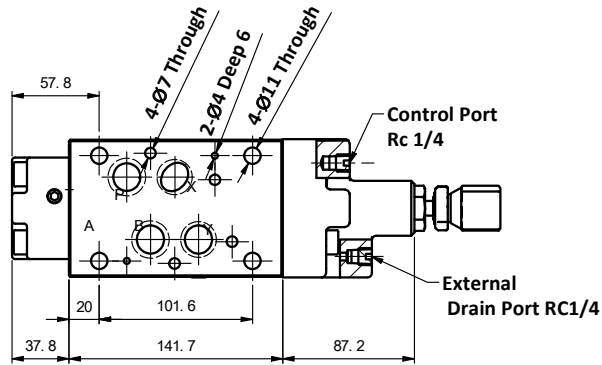

Hydraulic Symbol

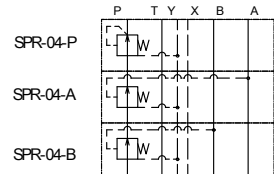

Adjustment way Increase

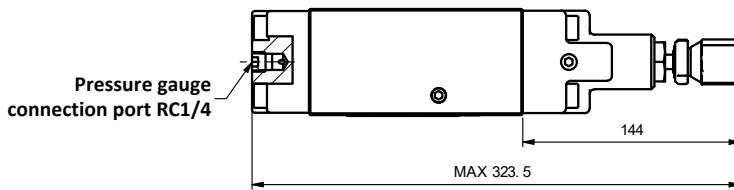
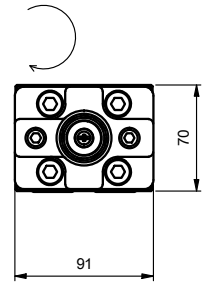

SPR-06 A/B/P
ISO 4401-AE-08-4-A

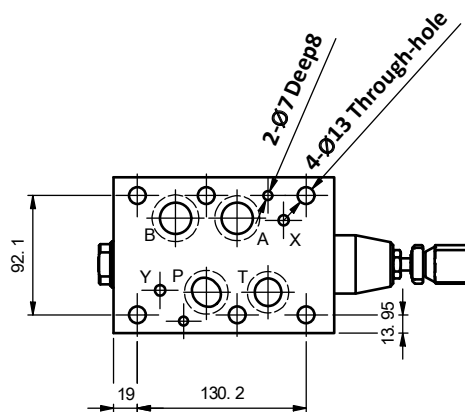

Hydraulic Symbol

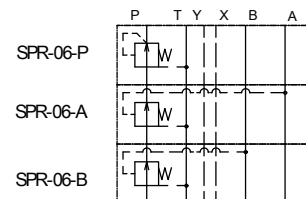

Adjustment way Increase

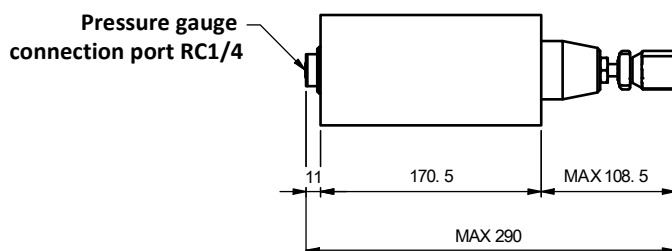
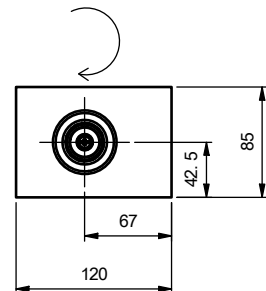

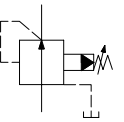

Modular Valves
Modular Reducing Valves

Modular Counterbalance Valves

JIS-Graphic Symbol

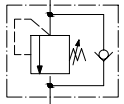
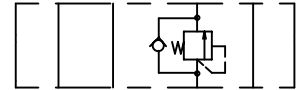

Model Description

SUC	-02	A	3
Model /Series	Thread Code Size (Inch)	Control Port	Pressure Adjustment Range Kg/cm ²
Modular Counterbalance Valves	02 : 1/4"	A: A Port B: B Port	1 : 7 - 35
	03 : 3/8"		2 : 35 - 70
	04 : 1/2"		3 : 70 - 140
	06 : 3/4"		4 : 140 - 210

Specification

Model	Operation Pressure (Max.) Kg/cm ²	Rated Flow (Max.) L/min
SUC-02	250	40
SUC-03		80
SUC-04		160
SUC-06		200



Dimensions

SUC-02A
ISO 4401-AB-03-4-A

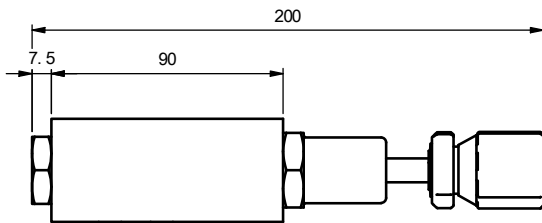
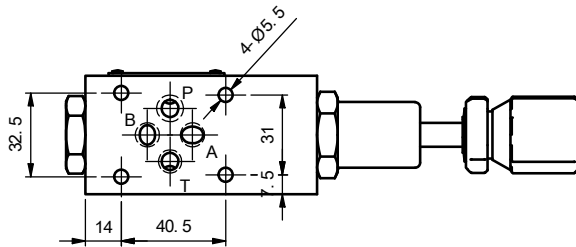

Hydraulic Symbol



Adjustment way Increase

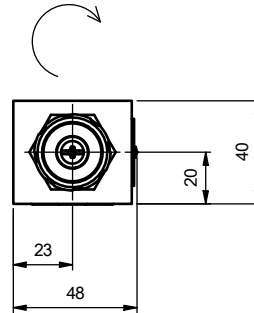

SUC-02B
ISO 4401-AB-03-4-A

Hydraulic Symbol



Adjustment way Increase

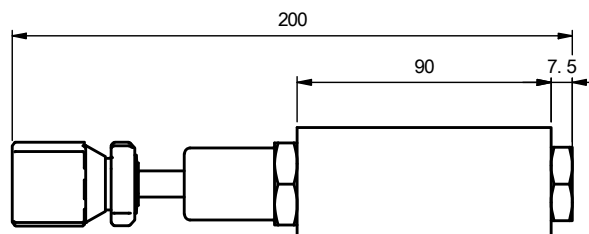
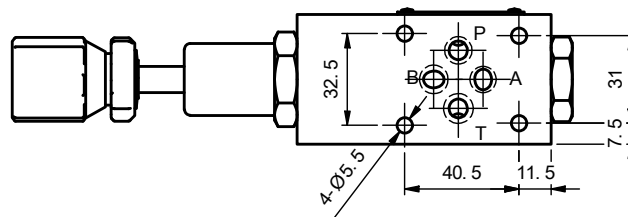
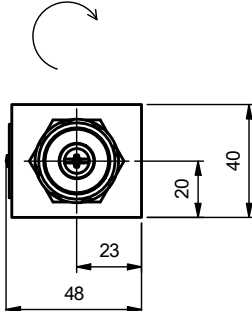

Dimensions

SUC-03A
ISO 4401-AC-05-4-A

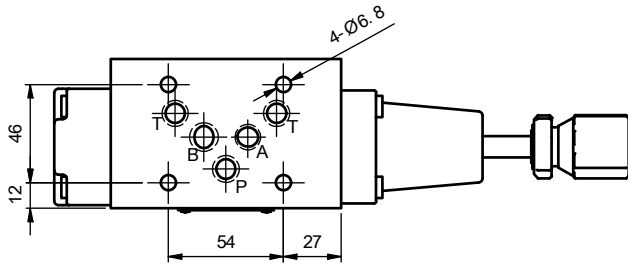

Hydraulic Symbol



Adjustment way Increase

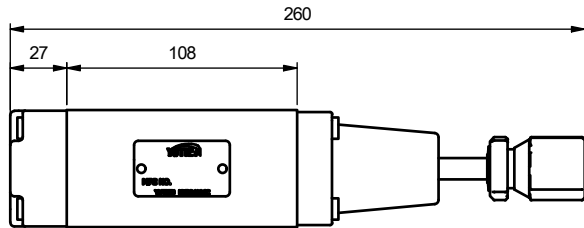
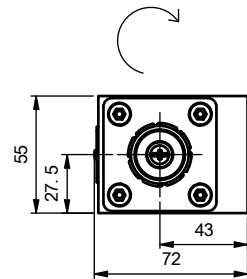

SUC-03B
ISO 4401-AC-05-4-A

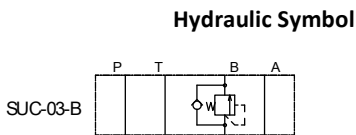

Adjustment way Increase

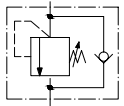
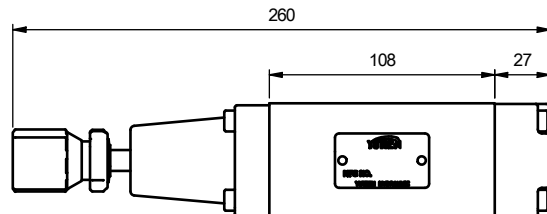
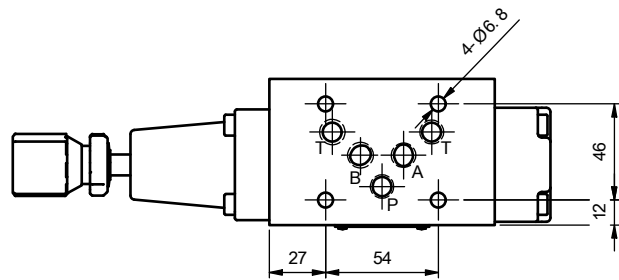
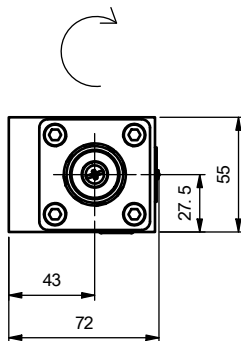

Dimensions

SUC-04A
ISO 4401-AD-07-4-A

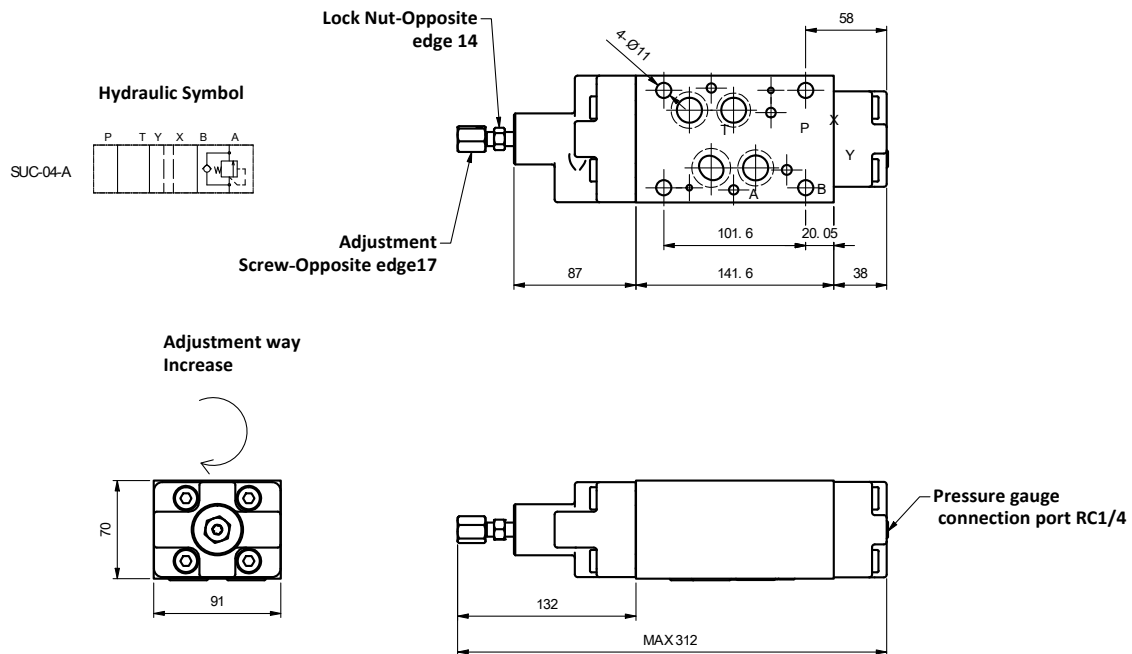

SUC-04B
ISO 4401-AD-07-4-A

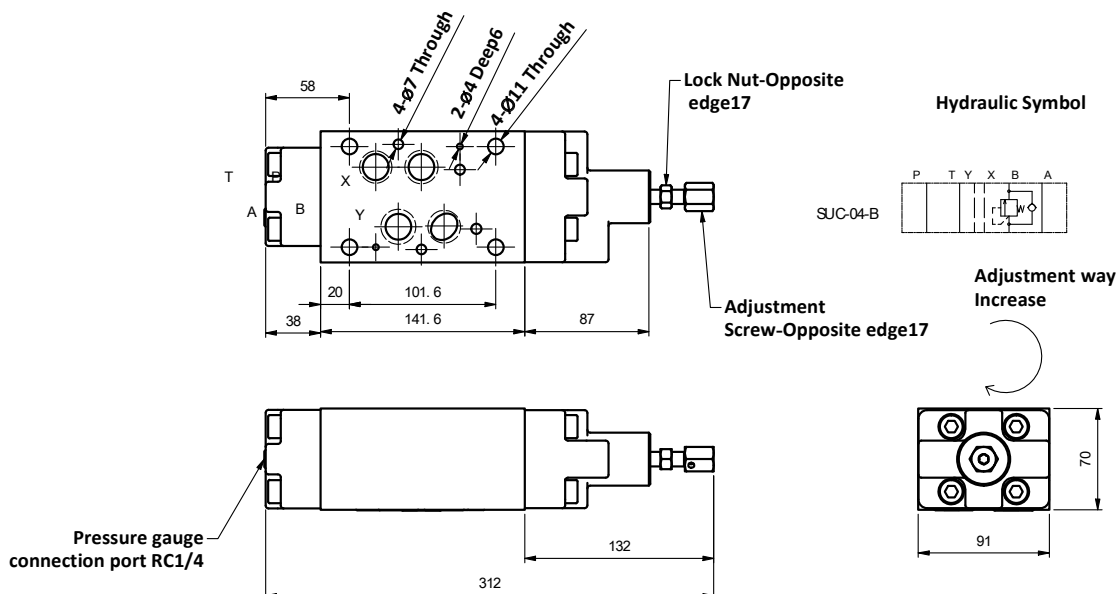

Modular Valves
Modular Counterbalance Valves

Dimensions

SUC-06A
ISO 4401-AE-08-4-A

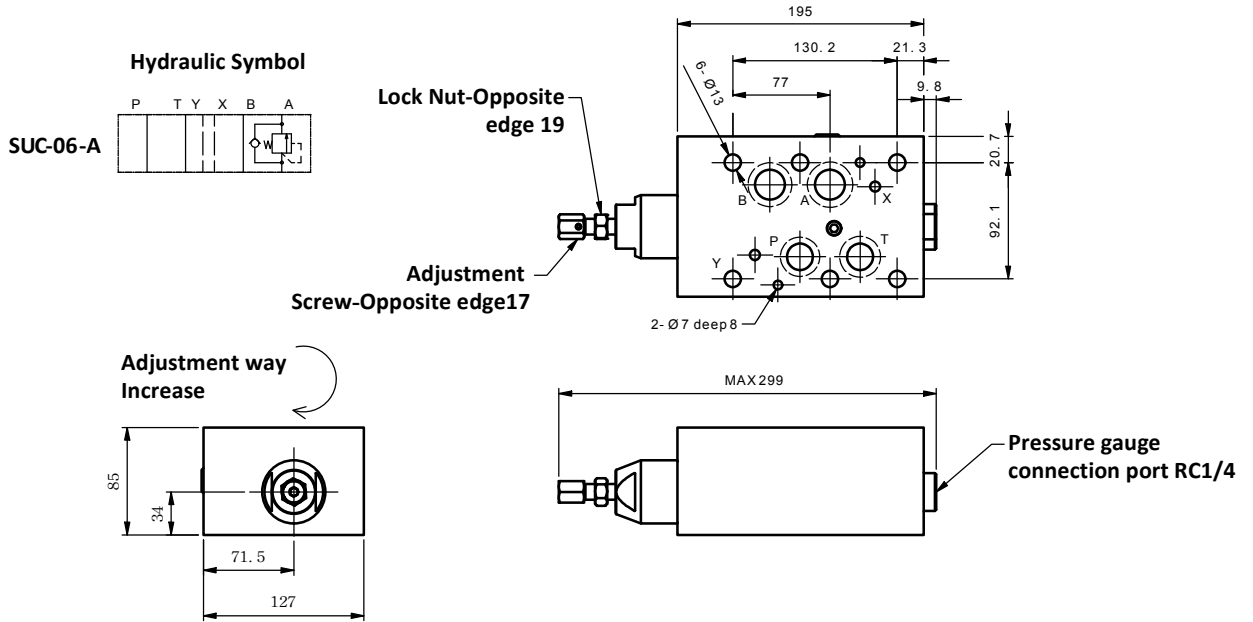

SUC-06B
ISO 4401-AE-08-4-A

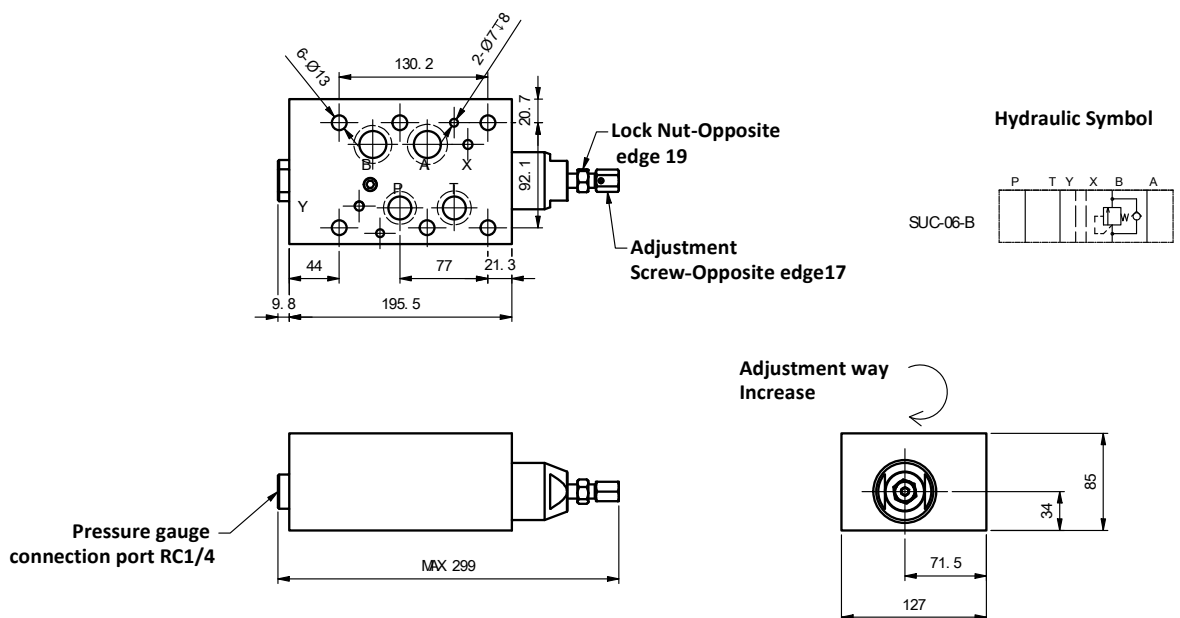

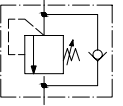

Modular Valves
Modular Counterbalance Valves

Modular Throttle Valves



JIS-Graphic Symbol



Model Description

STV	-02	P
Model /Series	Thread Code Size (Inch)	Control Port
Modular Throttle Valves	02 : 1/4" 03 : 3/8"	P: P Port T: T Port

Specification

Model	Operation Pressure (Max.) Kg/cm ²	Rated Flow (Max.) L/min
STV-02	250	40
STV-03		80

Dimensions

STV-02P
ISO 4401-AB-03-4-A

Hydraulic Symbol

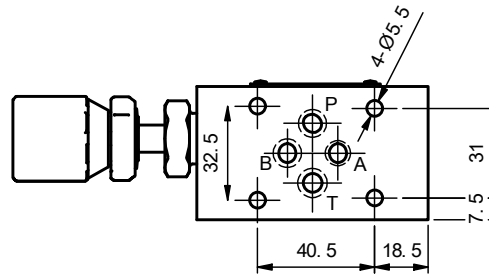

Adjustment way Increase

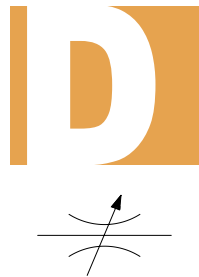
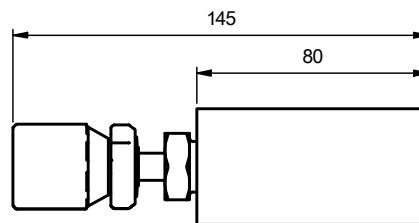
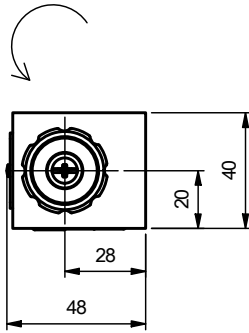

STV-02T
ISO 4401-AB-03-4-A

Hydraulic Symbol

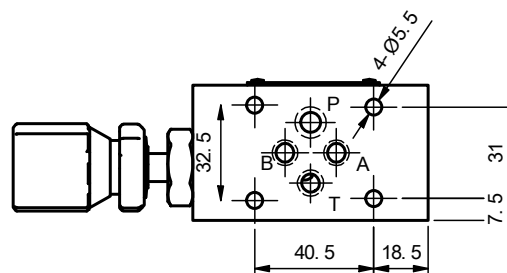
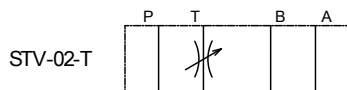

Adjustment way Increase

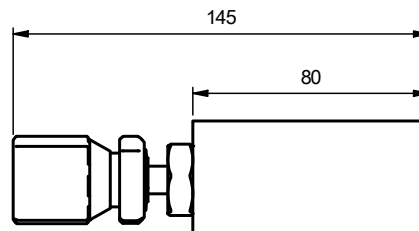
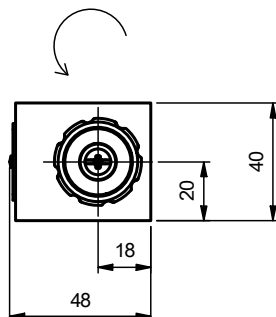

Modular Valves
Modular Throttle Valves

Dimensions

STV-03P
ISO 4401-AC-05-4-A

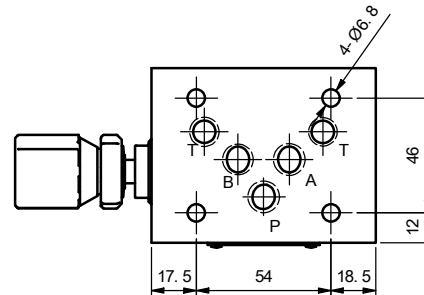
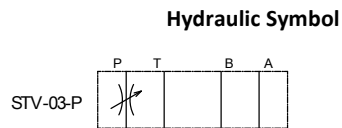

**Adjustment way
Decrease**

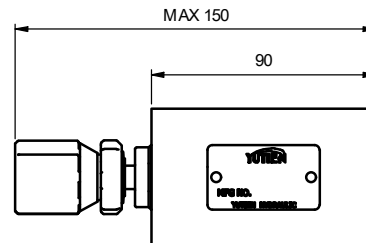
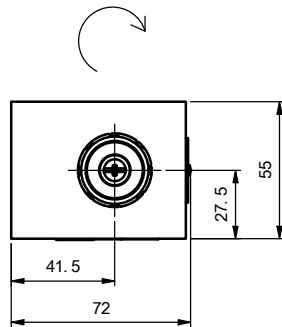

STV-03T
ISO 4401-AC-05-4-A

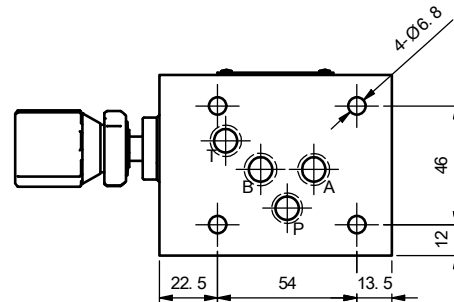
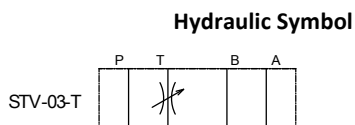

**Adjustment way
Decrease**

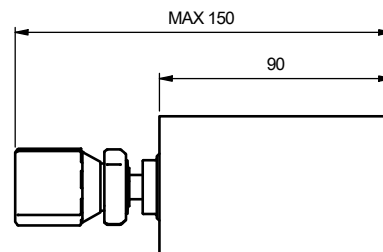
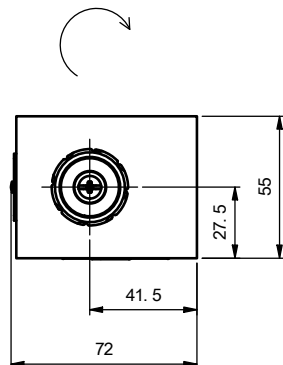

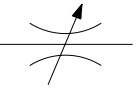

Modular Valves
Modular Throttle Valves

Modular Throttle and Check Valves



JIS-Graphic Symbol

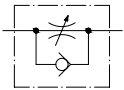
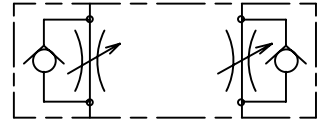

Model Description

STC	-02	W	Y
Model /Series	Thread Code Size (Inch)	Control Port	Control Type

Modular Throttle and Check Valves	02 : 1/4"	A: A Port	X: Oil Inlet Control Y: Oil Return Control
	03 : 3/8"	B: B Port	
	04 : 1/2"	P: P Port	
	06 : 3/4"	W: A&B Port	

Specification

Model	Operation Pressure (Max.) Kg/cm ²	Rated Flow (Max.) L/min	Flow Adjustment Range (Max.) L/min
STC-02	250	40	0.3-40
STC-03		80	0.5-80
STC-04		160	0.7-160
STC-06		200	1.0-190

Dimensions

STC-06W-X
ISO 4401-AB-03-4-A

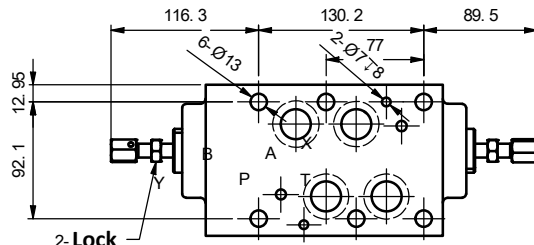
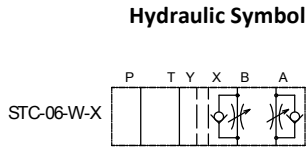

2-Lock
Nut-Opposite edge 17

Adjustment way
Increase

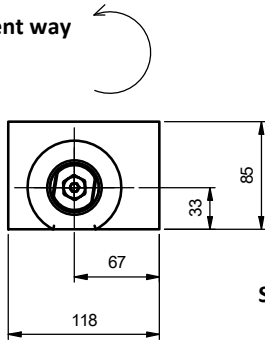

2-Adjustment
Screw-Opposite edge 17

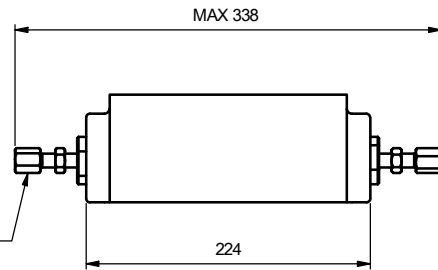

STC-06W-Y
ISO 4401-AB-03-4-A

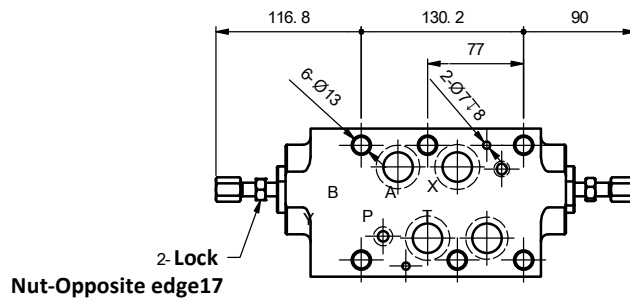
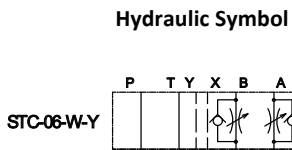

2-Lock
Nut-Opposite edge 17

Adjustment way
Increase

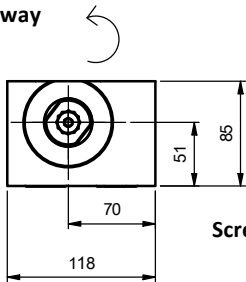

2-Adjustment
Screw-Opposite edge 17

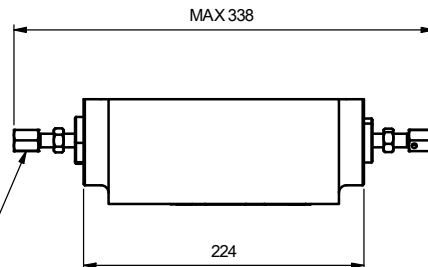

Modular Valves
Modular Throttle and Check Valves

Dimensions

STC-02W-X/Y
ISO 4401-AB-03-4-A

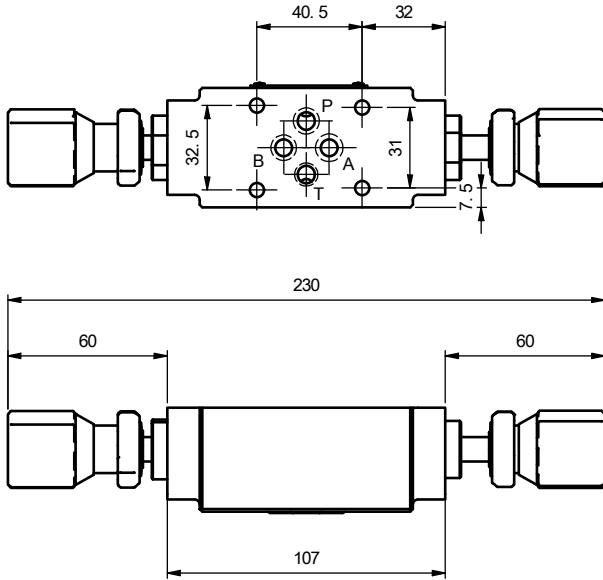

Hydraulic Symbol

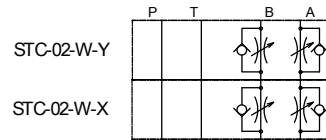

Adjustment way Increase

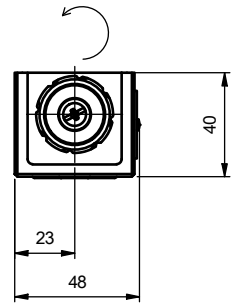

STC-03A-X/Y
ISO 4401-AC-05-4-A

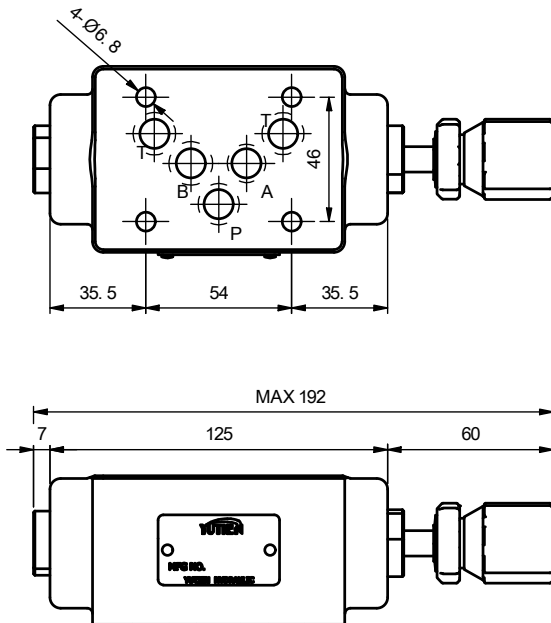

Hydraulic Symbol

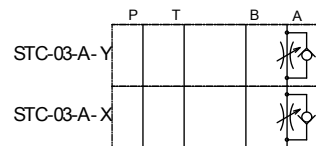

Adjustment way Increase

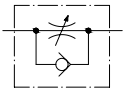
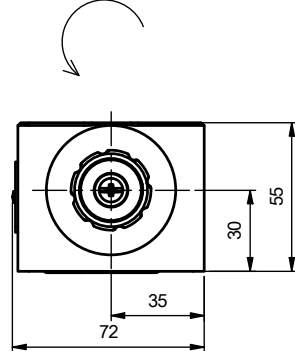

Modular Valves
Modular Throttle and Check Valves

Dimensions

STC-03B-X/Y
ISO 4401-AC-05-4-A

Hydraulic Symbol

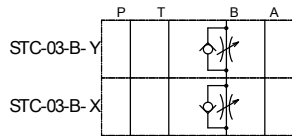

Adjustment way Increase

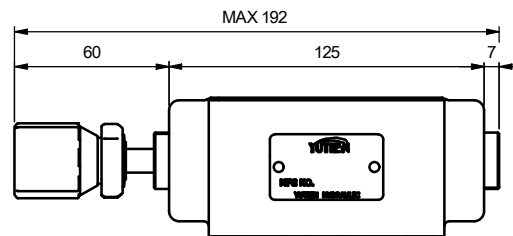
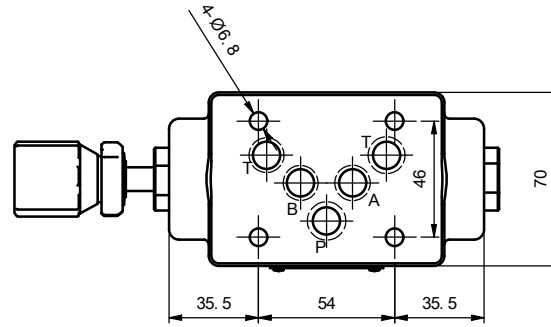
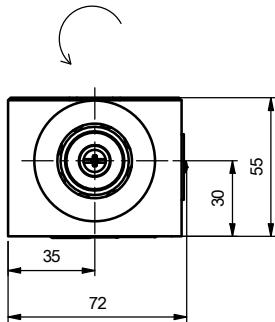

STC-03W-X/Y
ISO 4401-AC-05-4-A

Hydraulic Symbol

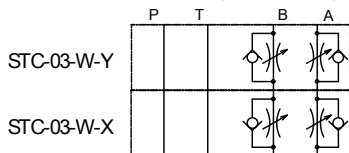

Adjustment way Increase

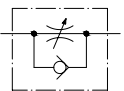
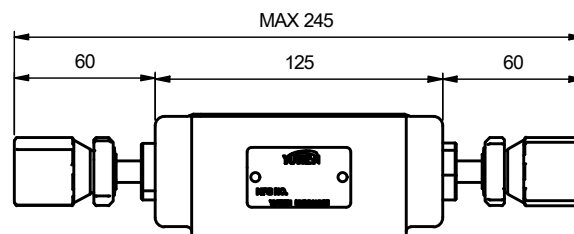
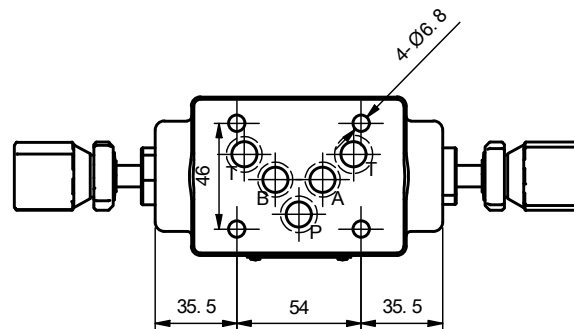
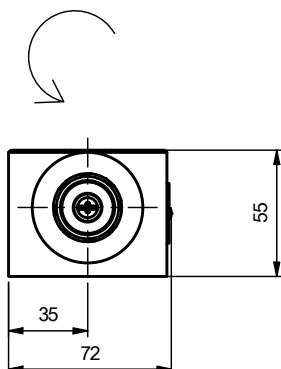

Modular Valves
Modular Throttle and Check Valves

Dimensions

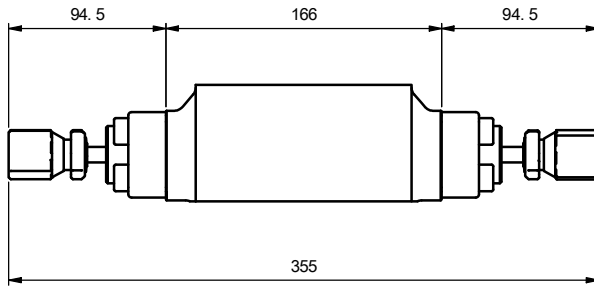
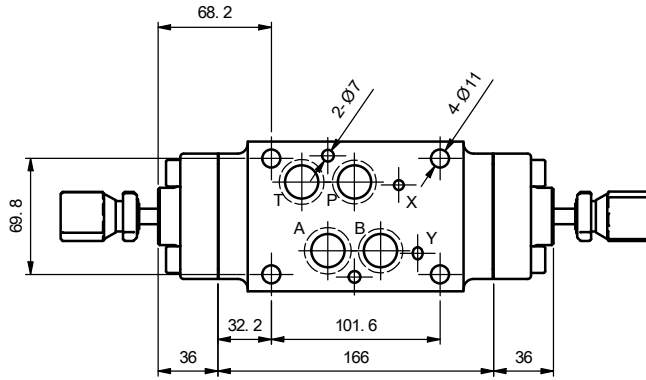

STC-04W-X
ISO 4401-AD-07-4-A

Hydraulic Symbol

	P	T	Y	X	B	A
STC-04-W-X						
STC-04-A-X						
STC-04-B-X						

Adjustment way
Increase

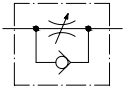
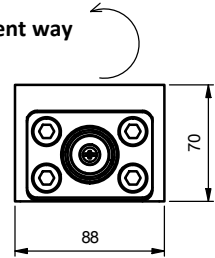

Modular Valves
Modular Throttle and Check Valves

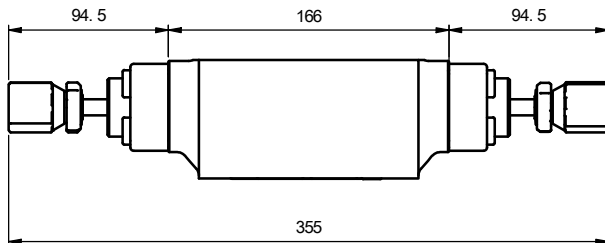
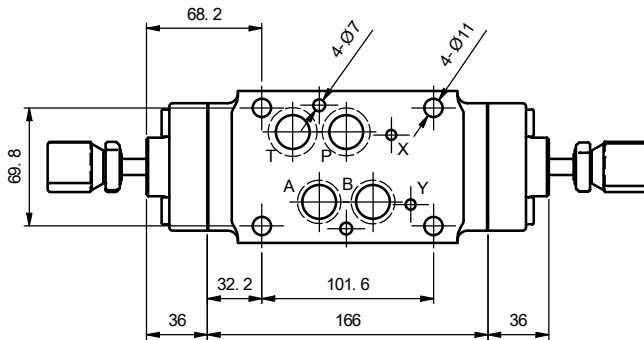

STC-04W-Y
ISO 4401-AD-07-4-A

Hydraulic Symbol

	P	T	Y	X	B	A
STC-04-W-Y						
STC-04-A-Y						
STC-04-B-Y						

Adjustment way
Increase

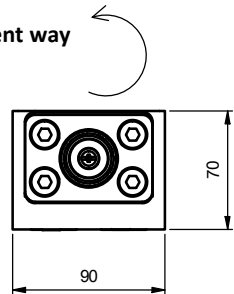

Dimensions

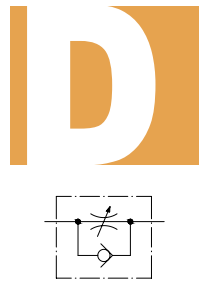
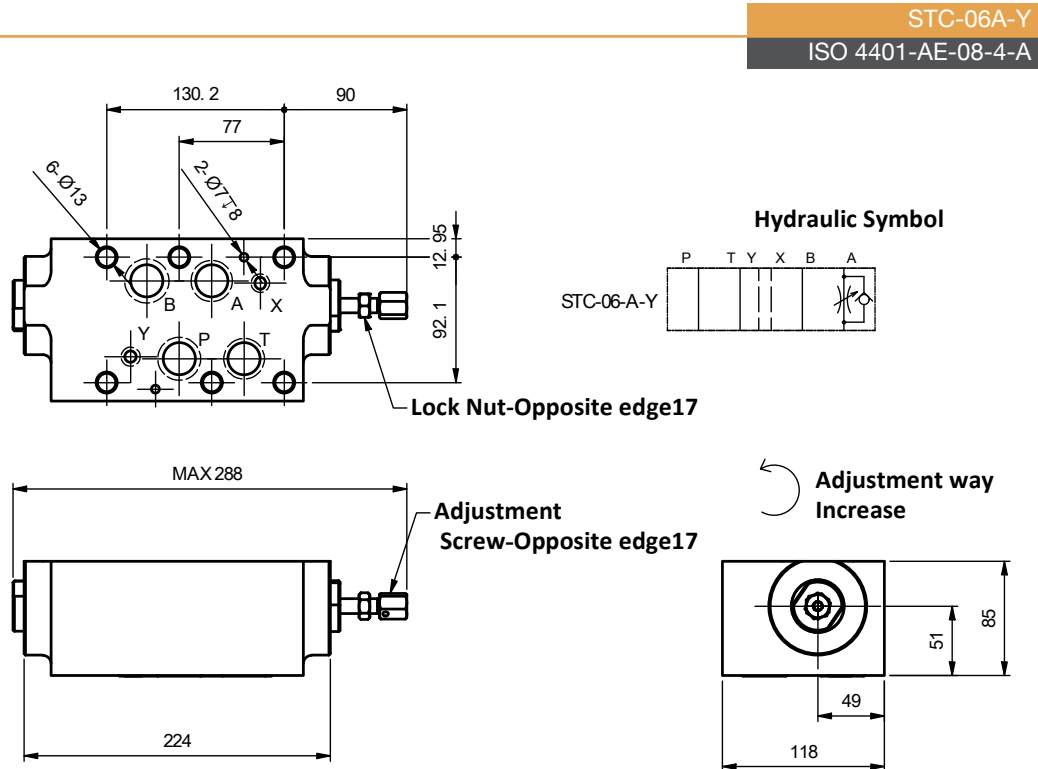
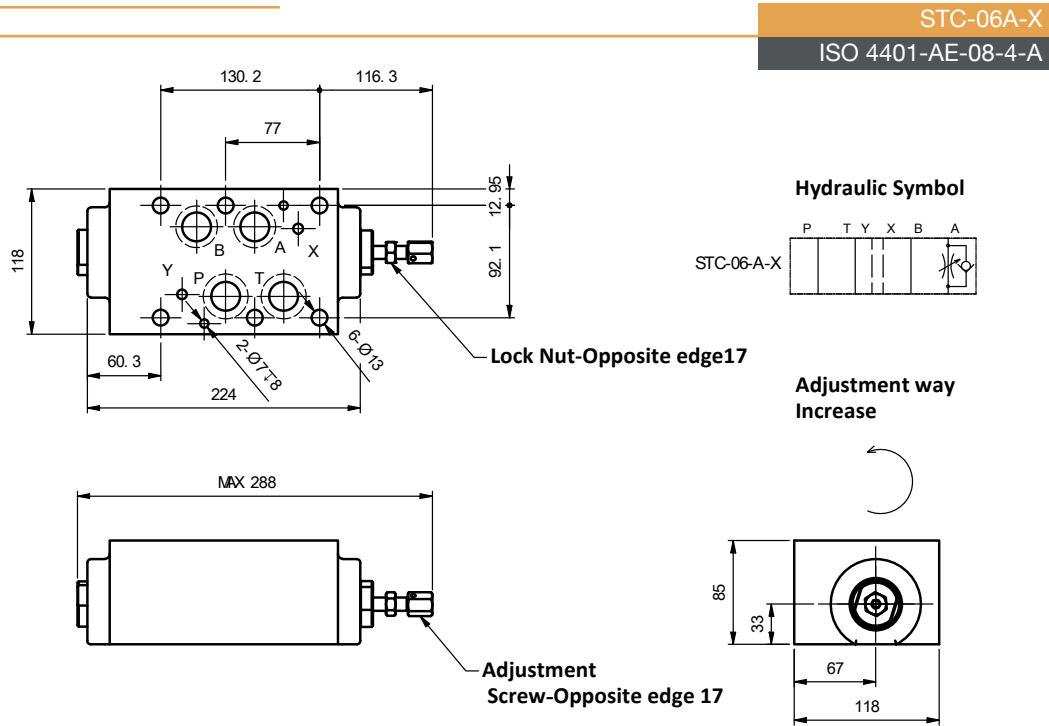

Modular Valves
Modular Throttle and Check Valves

Dimensions

STC-06B-X
ISO 4401-AE-08-4-A

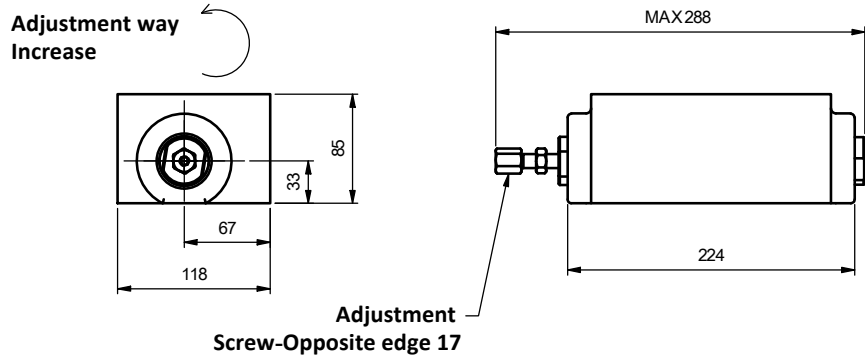
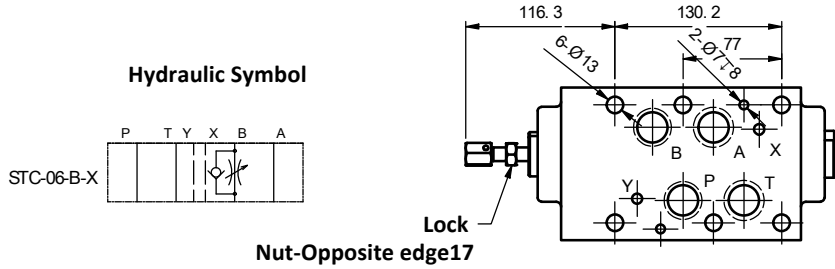

STC-06B-Y
ISO 4401-AE-08-4-A

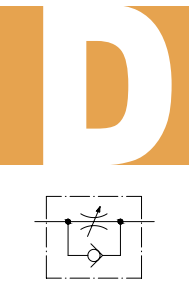
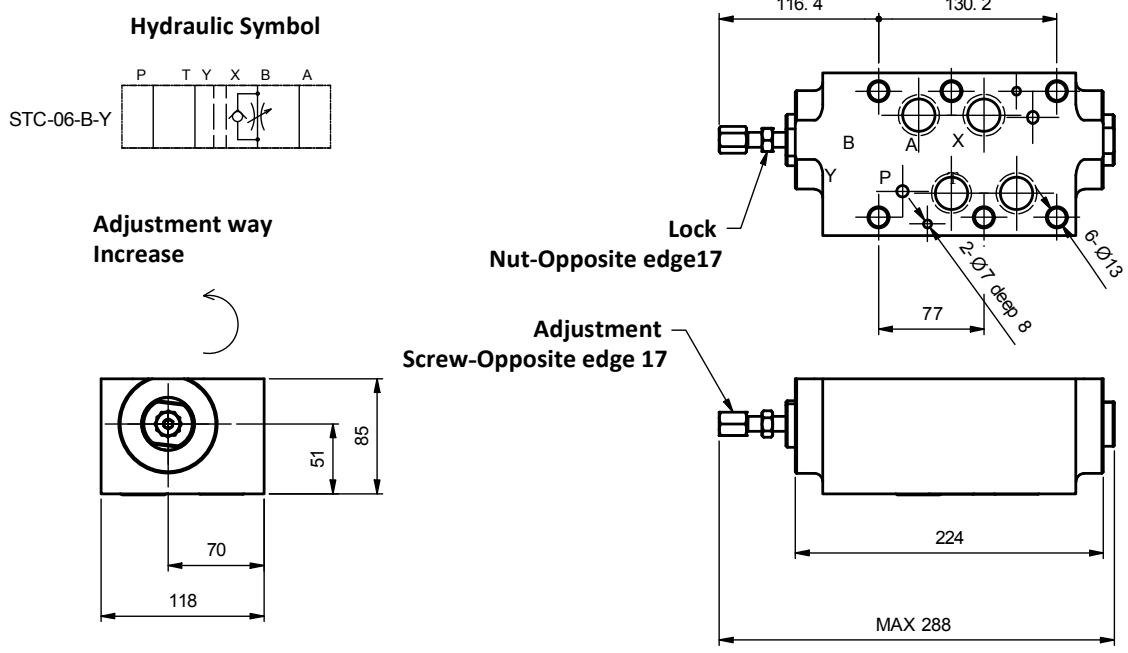

Modular Valves
Modular Throttle and Check Valves

Dimensions

STC-06-W-X
ISO 4401-AE-08-4-A

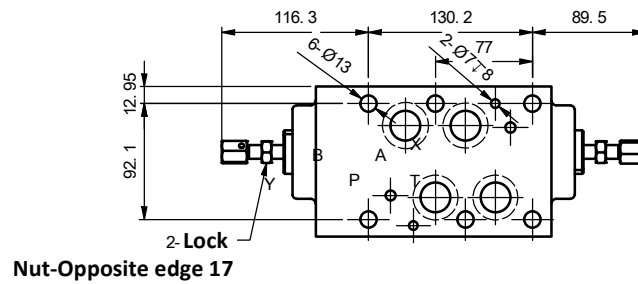
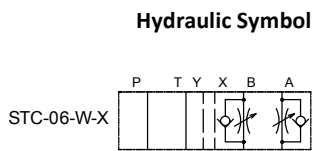

Adjustment way
Increase

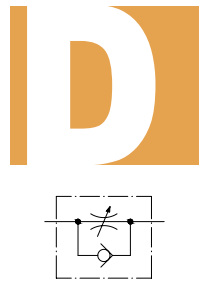
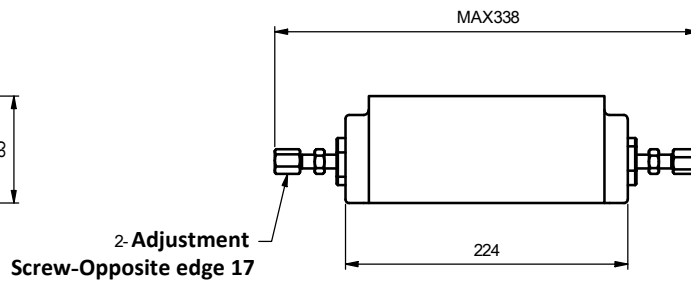
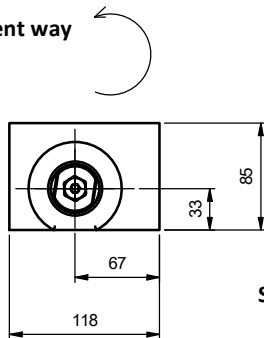

STC-06-W-Y
ISO 4401-AE-08-4-A

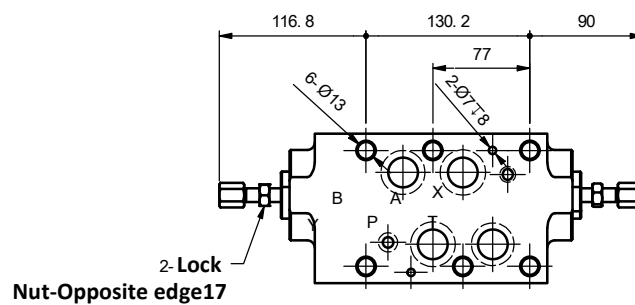
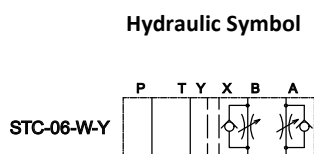

Adjustment way
Increase

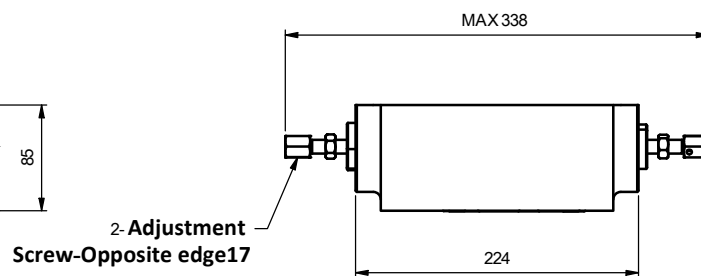
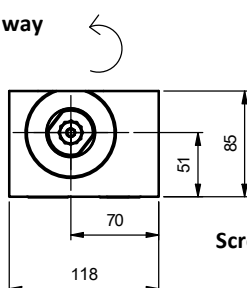

Modular Valves
Modular Throttle and Check Valves

Modular Check Valves



JIS-Graphic Symbol

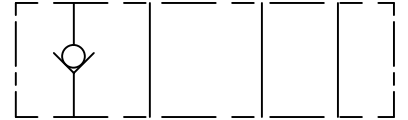

Model Description

SCV	-02	P	50
Model /Series	Thread Code Size (Inch)	Control Port	Cracking Pressure Kg/cm ²
Modular Check Valves	02 : 1/4" 03 : 3/8"	A: A Port B: B Port P: P Port T: T Port W: A&B Port	05 : 0.5 50 : 5

Specification

Model	Operation Pressure (Max.) Kg/cm ²	Rated Flow (Max.) L/min
SCV-02	250	40
SCV-03		80

Dimensions

SCV-02-A
ISO 4401-AB-03-4-A

Hydraulic Symbol

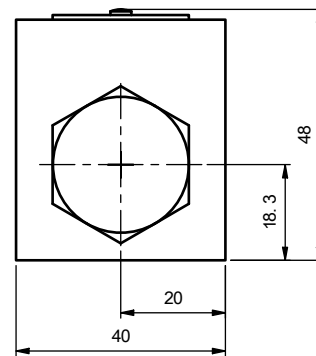
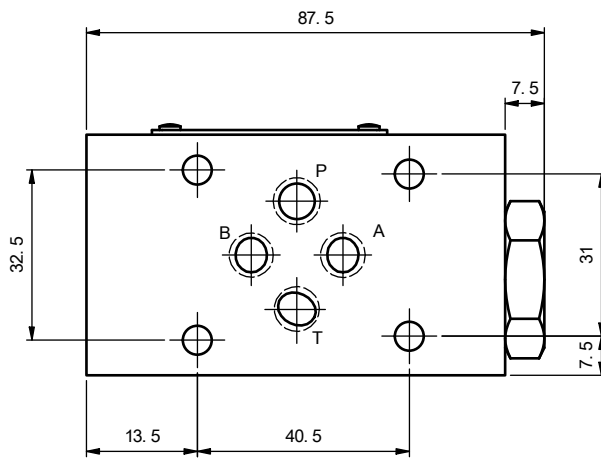
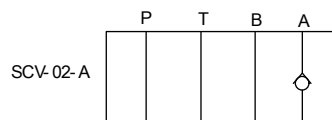

SCV-02-B
ISO 4401-AB-03-4-A

Hydraulic Symbol

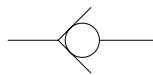
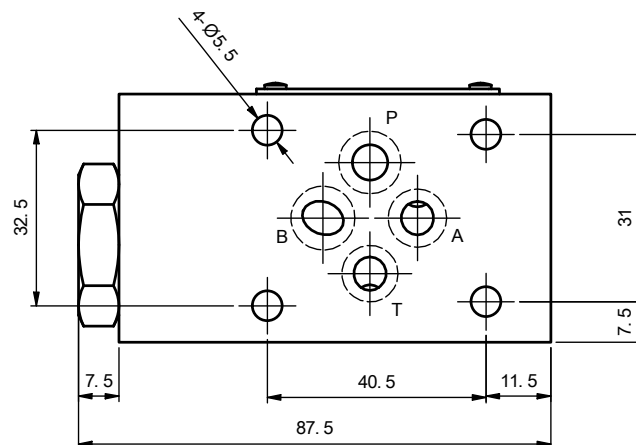
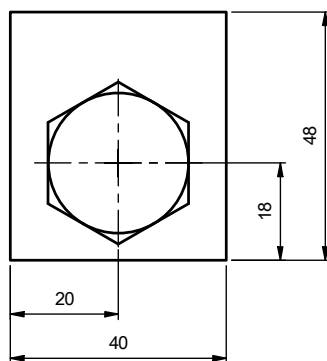

Modular Valves
Modular Check Valves

Dimensions

SCV-02-P
ISO 4401-AB-03-4-A

Hydraulic Symbol

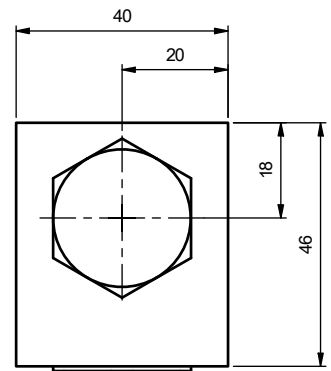
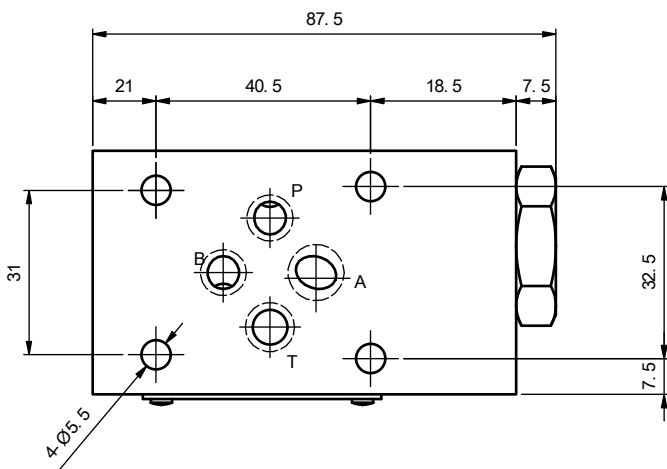
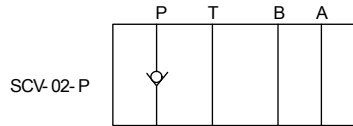

SCV-02-T
ISO 4401-AB-03-4-A

Hydraulic Symbol

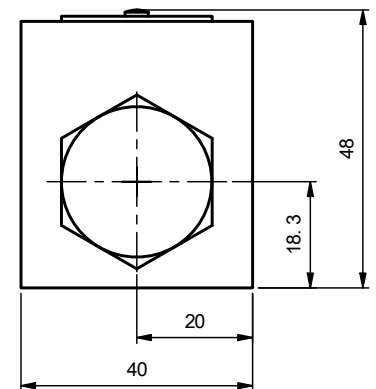
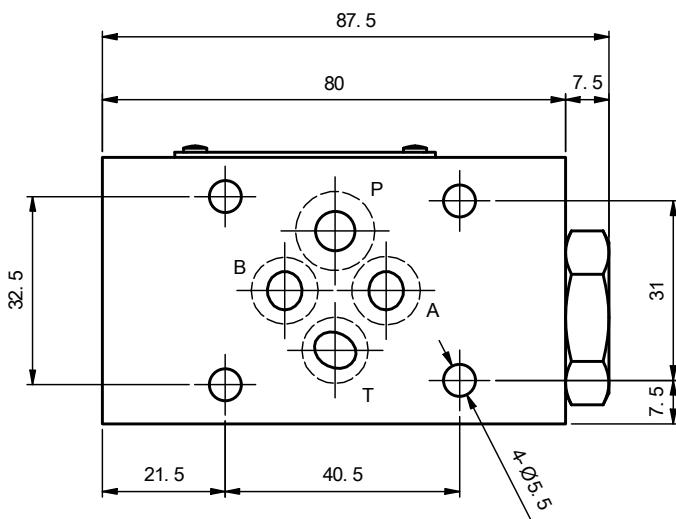
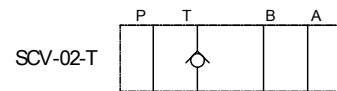

Modular Valves
Modular Check Valves

Dimensions

SCV-02-W
ISO 4401-AB-03-4-A

Hydraulic Symbol

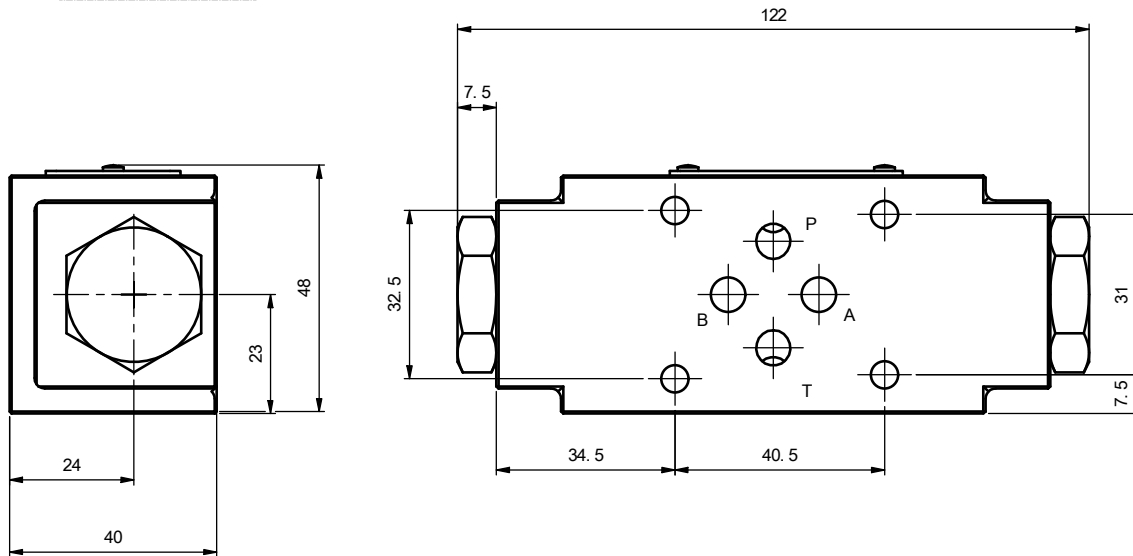

SCV-03-A
ISO 4401-AC-05-4-A

Hydraulic Symbol

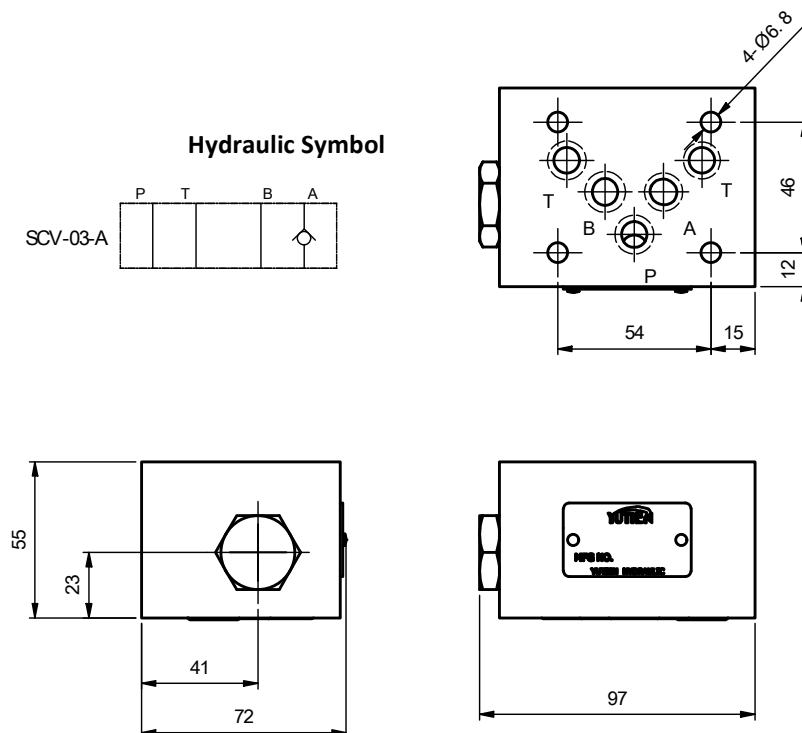
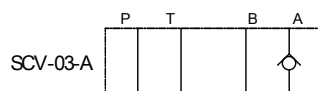

Modular Valves
Modular Check Valves

Dimensions

SCV-03-B

ISO 4401-AC-05-4-A

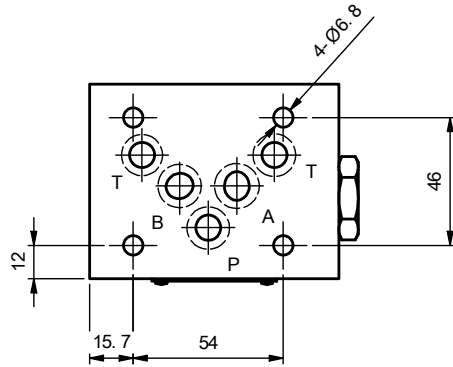

Hydraulic Symbol

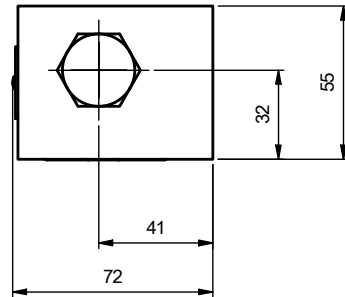
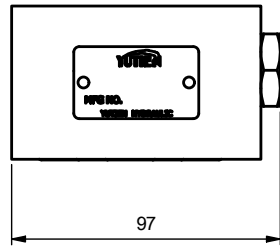

SCV-03-P

ISO 4401-AC-05-4-A

Hydraulic Symbol

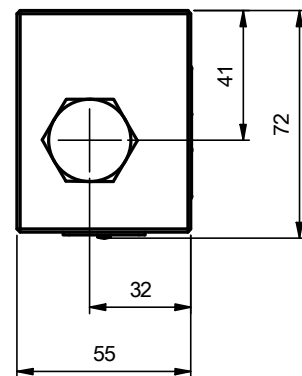
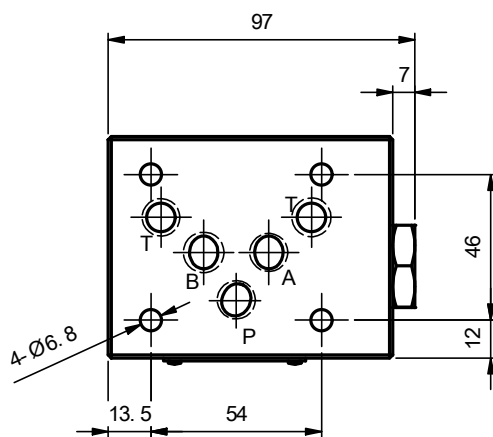
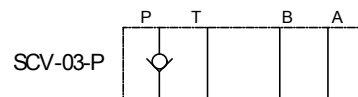

Dimensions

SCV-03-T
ISO 4401-AC-05-4-A

Hydraulic Symbol

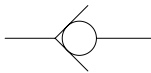
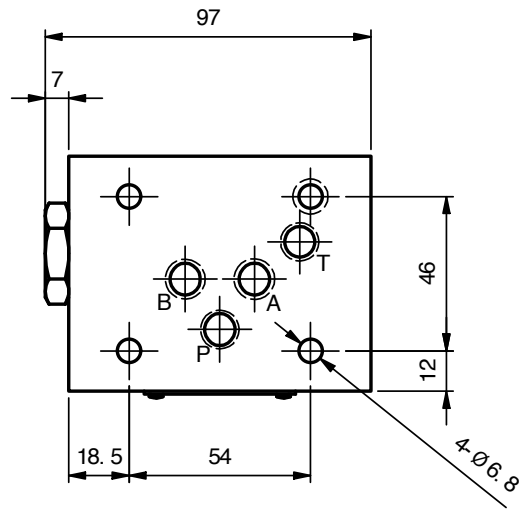
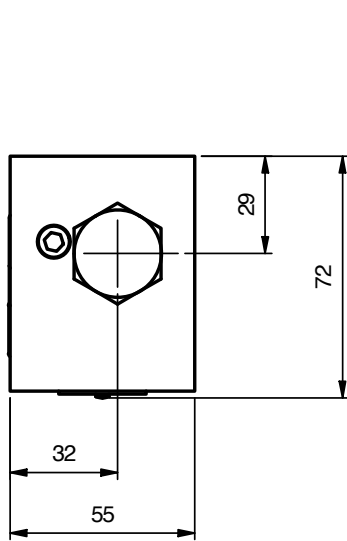
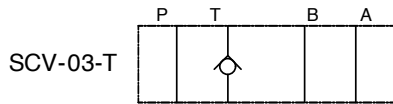

Modular Valves
Modular Check Valves

Modular Pilot Operated Check Valves



JIS-Graphic Symbol

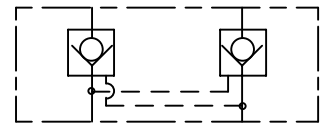

Model Description

SPV	-02	W	50
Model /Series	Thread Code Size (Inch)	Control Port	Cracking Pressure Kg/cm ²
Modular Pilot Operated Check Valves	02 : 1/4"	W: A&B Port A: A Port B: B Port	05 : 0.5
	03 : 3/8"		50 : 5
	04 : 1/2"		
	06 : 3/4"		

Specification

Model /Type	Operation Pressure (Max.) Kg/cm ²	Rated Flow (Max.) L/min
SPV-02	250	40
SPV-03		80
SPV-04		160
SPV-06		190

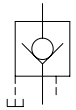

Dimensions

SPV-02-A/B/W
ISO 4401-AB-03-4-A

Hydraulic Symbol

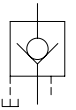
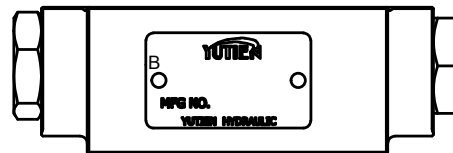
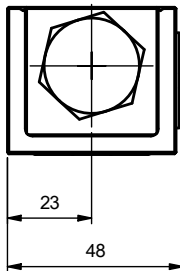
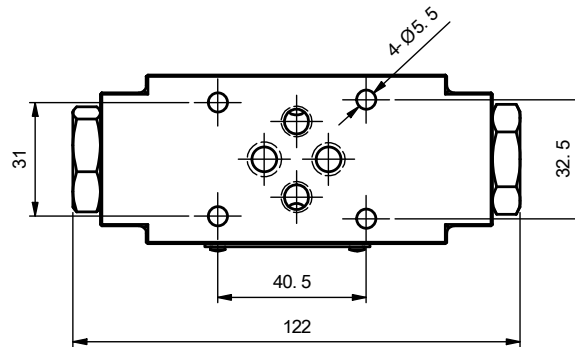
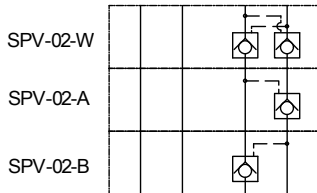

SPV-03-A/B/W
ISO 4401-AC-05-4-A

Hydraulic Symbol

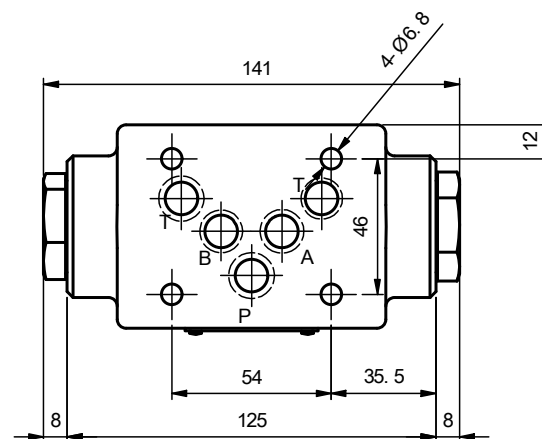
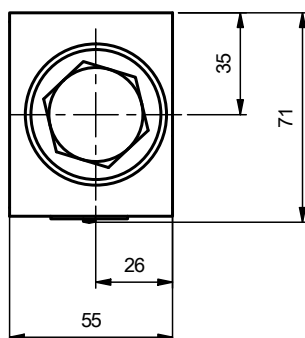
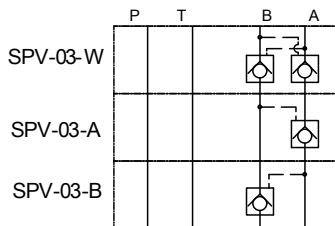

Modular Valves
Modular Pilot Operated Check Valves

Dimensions

SPV-04-A/B/W

ISO 4401-AD-07-4-A

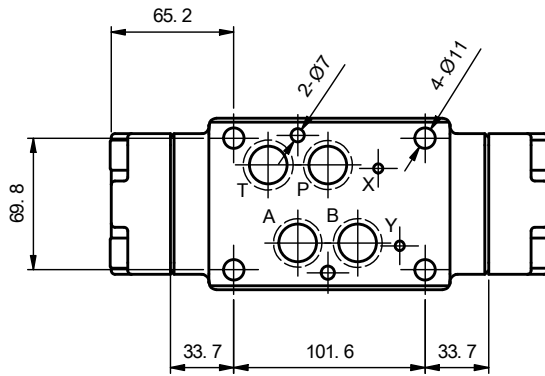

Hydraulic Symbol

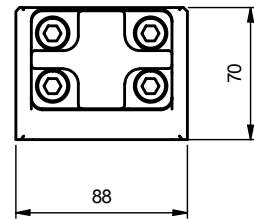
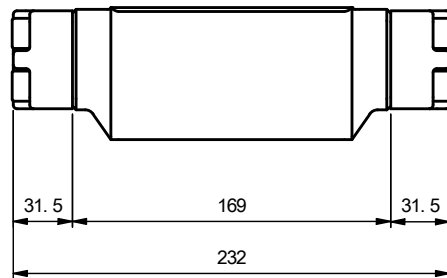
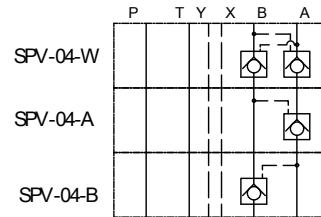

SPV-06-A/B/W

ISO 4401-AE-08-4-A

Hydraulic Symbol

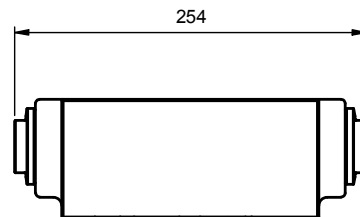
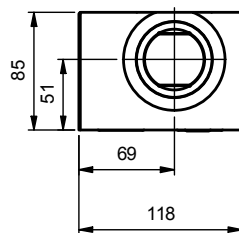
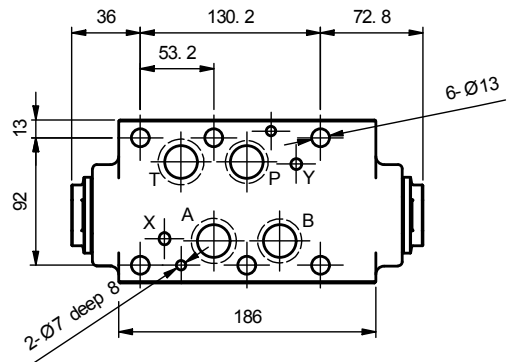
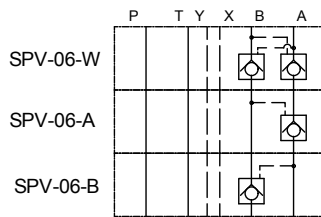

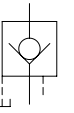



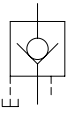

Modular Valves
Modular Pilot Operated Check Valves

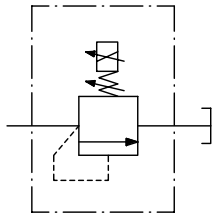

Modular Valves
Modular Pilot Operated Check Valves

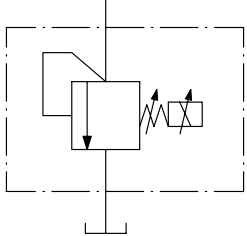
E Proportional Valves

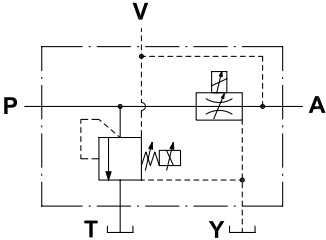
ITEM PICTURE	JIS GRAPHIC SYMBOL	PRODUCT NAME	PAGE
		<p>Proportional Electro-Hydraulic Pilot Relief Valves</p>	<p>2</p>
		<p>Proportional Electro-Hydraulic Relief Valves</p>	<p>4</p>
		<p>Proportional Electro-Hydraulic Relief & Flow Control Valves</p>	<p>6</p>

Proportional Electro-Hydraulic Pilot Relief Valves



JIS-Graphic Symbol

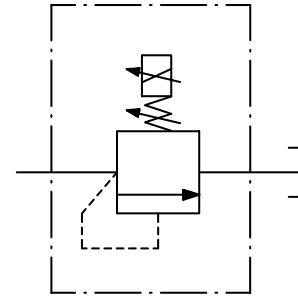

Feature

- Simplify the hydraulic system circuit, break through the traditional complex circuit of "one-pressure with one-remote control valve".
- The proportional coil can produce step-less pressure based on the input current and bring out

the best function of combination the hydraulics and electronics.

- With fast response function, transient pressure changes are small, which can reduce pipeline resonance.

Model Description

EDG	-01	-C
Model /Series	Thread Code Size (Inch)	Pressure Adjustment Range kgf/cm ²
Proportional Electro-Hydraulic Pilot Relief Valves	01 : 1/8"	C : 140 H : 210

Specification

Model	Operating Pressure (Max.) kgf/cm ²	Rated Flow (Max.) L/min	Flow Adjustment Range (Max.) L/min	Allowable Back Pressure kgf/cm ²
EDG-01	210	2	C : 8~140 H : 10~210	Note
Rated Current (mA)	Coil Resistance Ω	Hysteresis %	Reproducibility %	Weight Kg
C : 750 H : 700	10	< 3	< 0.5	2

Note: The resistance of the return line should be cut down by using only one pipe insert into the tank (below the oil level) directly.

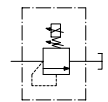

Instructions

- **Installation Position:** The air vent port must be upward. If the valve must be installed vertically, please contact our sales department.
- **Air Exhaust :** To stabilize the pressure, the air in the pipeline and the valve must be completely exhausted. Open the air vent screw to exhaust the air via upward vent port, and then lock the screw until there are no bubbles.
- **Manual Pressure Adjusting Screw:** When the electrical control fails and requires pressure, the manual pressure adjusting screw can be screwed in; it will return to its original position under normal conditions.
- **Oil Return line:** Please directly insert the return lines into the tank (below the oil level) to avoid the pipe from bending or resisting.
- **Pressure setting (Max.):** Based on actual output flow of the pump and actual operating pressure. Users are advised to add 15kgf/cm² when pump is under than 100 L/min.

Dimensions

EDG-01

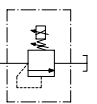
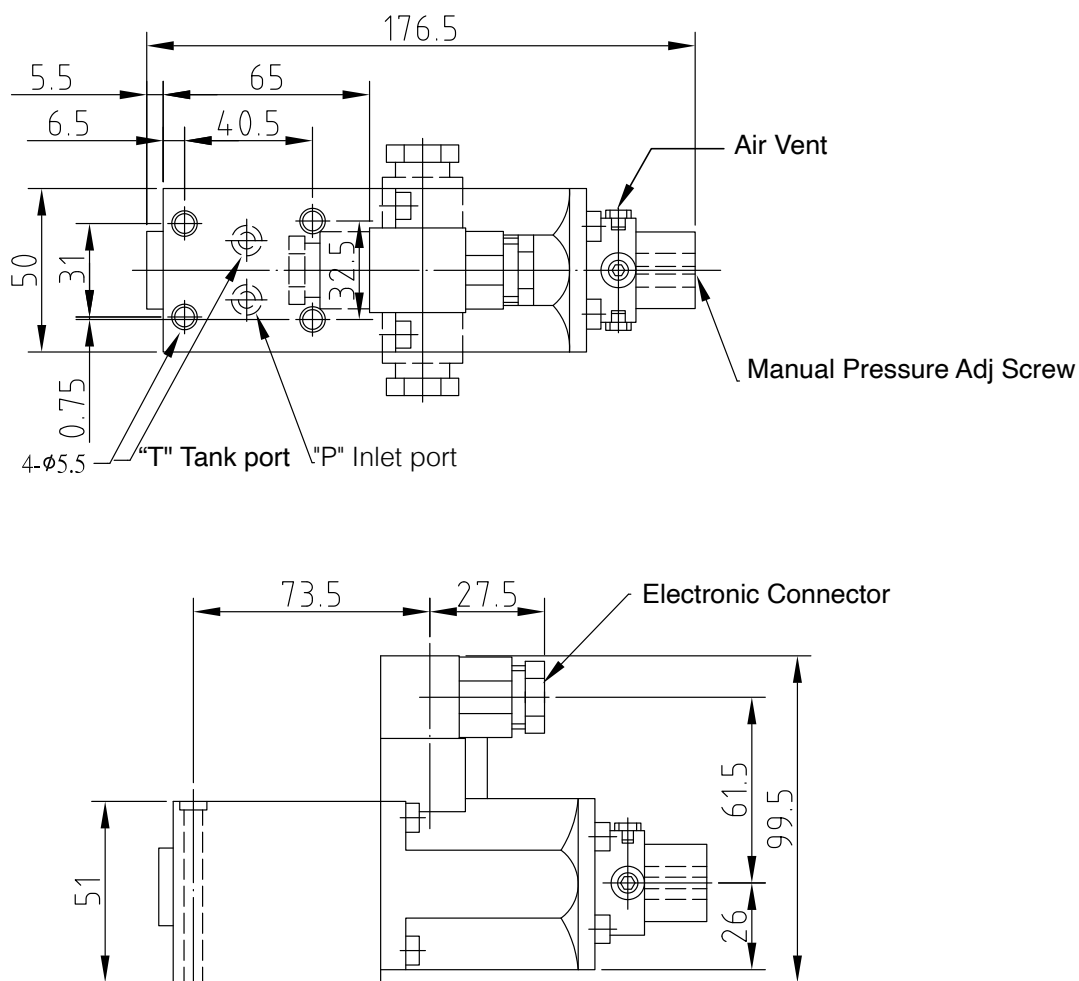

Proportional Valves
Proportional Electro-Hydraulic
Pilot Relief Valves

Proportional Electro-Hydraulic Relief Valves



JIS-Graphic Symbol

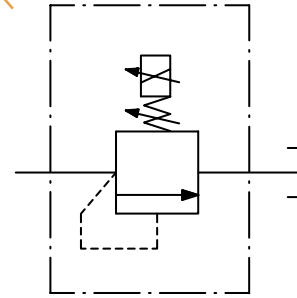

Feature

- EBG valve is stable pressure and low noise.
- High precision, easy fine-tuning, and shock pressures is small when pressure changes.
- Combine traditional and micro-computer electrical control to achieve the best combination of hydraulic and electronic functions.

Specification

Model /Type	Rated Flow (Max.) L/min	Operating Pressure (Max.) Mpa	Allowable Back Pressure Mpa	Rated Current (mA)
EBG-03	100	21	Note	C : 750 H : 700
EBG-06	200			

Coil Resistance Ω	Hysteresis %	Reproducibility %	Weight Kg
10	< 3	< 0.5	7.1
			8.3

Note: The resistance of the return line should be cut down by using only one pipe insert into the tank (below the oil level) directly.

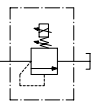

Instructions

- **Installation Position:** The air vent port must be upward. If the valve must be installed vertically, please contact our sales department.
- **Air Exhaust :** To stabilize the pressure, the air in the pipeline and the valve must be completely exhausted. Open the air vent screw to exhaust the air via upward vent port, and then lock the screw until there are no bubbles.
- **Manual Pressure Adjusting Screw:** When the electrical control fails and requires pressure, the manual pressure adjusting screw can be screwed in; it will return to its original position under normal conditions.
- **Oil Return line:** Please directly insert the return lines into the tank (below the oil level) to avoid the pipe from bending or resisting.
- **Pressure setting (Max.):** Based on actual output flow of the pump and actual operating pressure. Users are advised to add 15kgf/cm² when pump is under than 100 L/min.

Dimensions

EBG-03/06/10

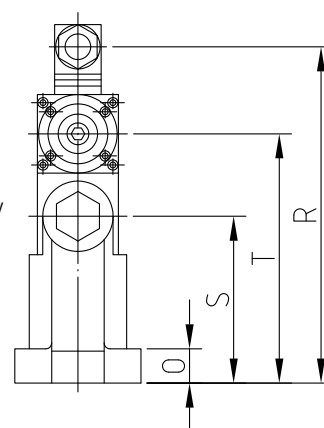
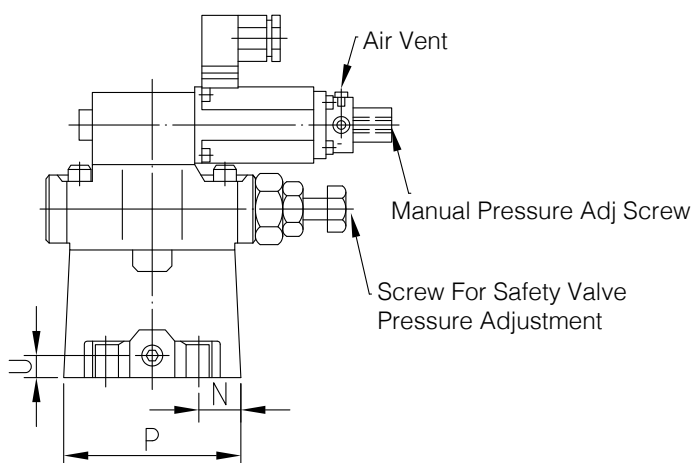
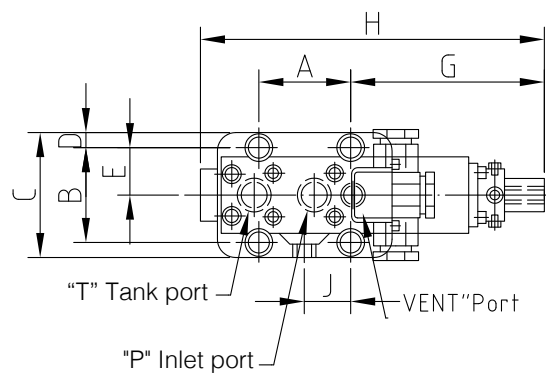

Model	A	B	C	D	E	G	H	J	N	P	Q	R	S	T	U
EBG-03	53.8	53.8	76	11	27	115	206	27	26	106	21.5	219	105	152	13
EBG-06	66.7	70	98	14	35	117	210	33	36	124	26	220	105	153	13

Proportional Electro-Hydraulic Relief & Flow Control Valves



JIS-Graphic Symbol

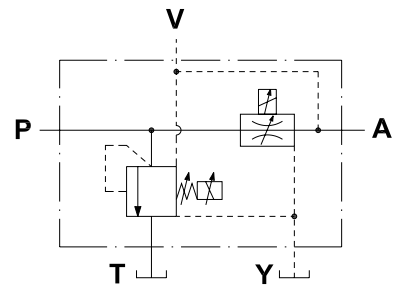

Model Description

EFBG	-03	-125	-C
Model /Series	Thread Code Size (Inch)	Rated Flow (Max.)	Pressure Adjustment Range kgf/cm ²
Proportional Electro-Hydraulic Relief & Flow Control Valves	03 : 3/8"	125	C : 140
	06 : 3/4"	250	H : 210
	10 : 1-1/4"	500	

Specification

Model	Operating Pressure (Max.) kgf/cm ²	Rated Flow (Max.) L/min	Pressure Adjustment Range kgf/cm ²	Weight kg
EFBG-03	210	125	1~125	18
EFBG-06		250	2~250	33
EFBG-10		500	5~500	58

Flow System					Pressure System				
Valve Internal Resistance (A → B) kgf/cm ²	Rated Current (mA)	Coil Resistance Ω	Hysteresis %	Reproducibility %	Allowable Back Pressure kgf/cm ²	Rated Current (mA)	Coil Resistance Ω	Hysteresis %	Reproducibility %
5	750	40	< 7	< 1	Note	C : 750 H : 700	10	< 3	< 1

Note: The resistance of the return line should be cut down by using only one pipe insert into the tank (below the oil level) directly.

Instructions

- **Installation Position:** The air vent port must be upward. If the valve must be installed vertically, please contact our sales department.
- **Air Exhaust :** To stabilize the pressure, the air in the pipeline and the valve must be completely exhausted. Open the air vent screw to exhaust the air via upward vent port, and then lock the screw until there are no bubbles.
- **Manual Pressure Adjusting Screw:** When the electrical control fails and requires pressure, the manual pressure adjusting screw can be screwed in; it will return to its original position under normal conditions.
- **Oil Return line:** Please directly insert the return lines into the tank (below the oil level) to avoid the pipe from bending or resisting.
- **Pressure setting (Max.):** Based on actual output flow of the pump and actual operating pressure. Users are advised to add 15kgf/cm² when pump is under than 100 L/min.

Dimensions

EFBG-03

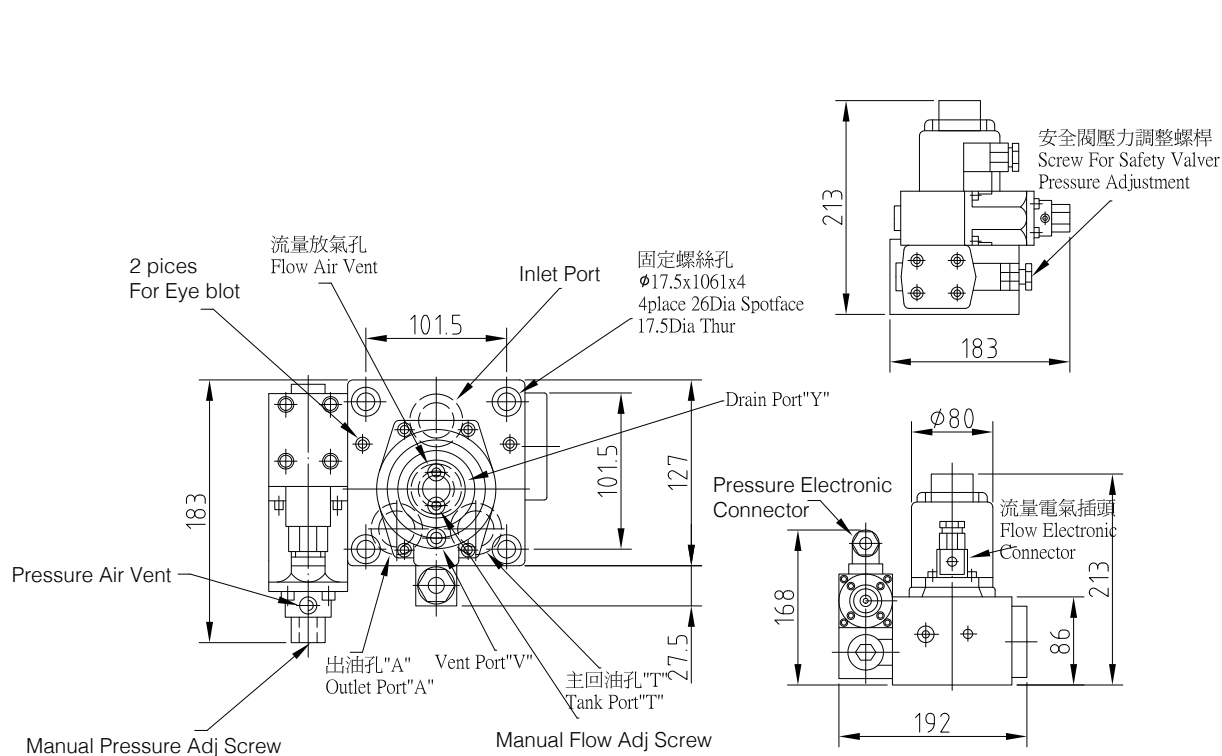

Proportional Valves
Proportional Electro-Hydraulic Relief &
Flow Control Valves

Dimensions

EFBG-06

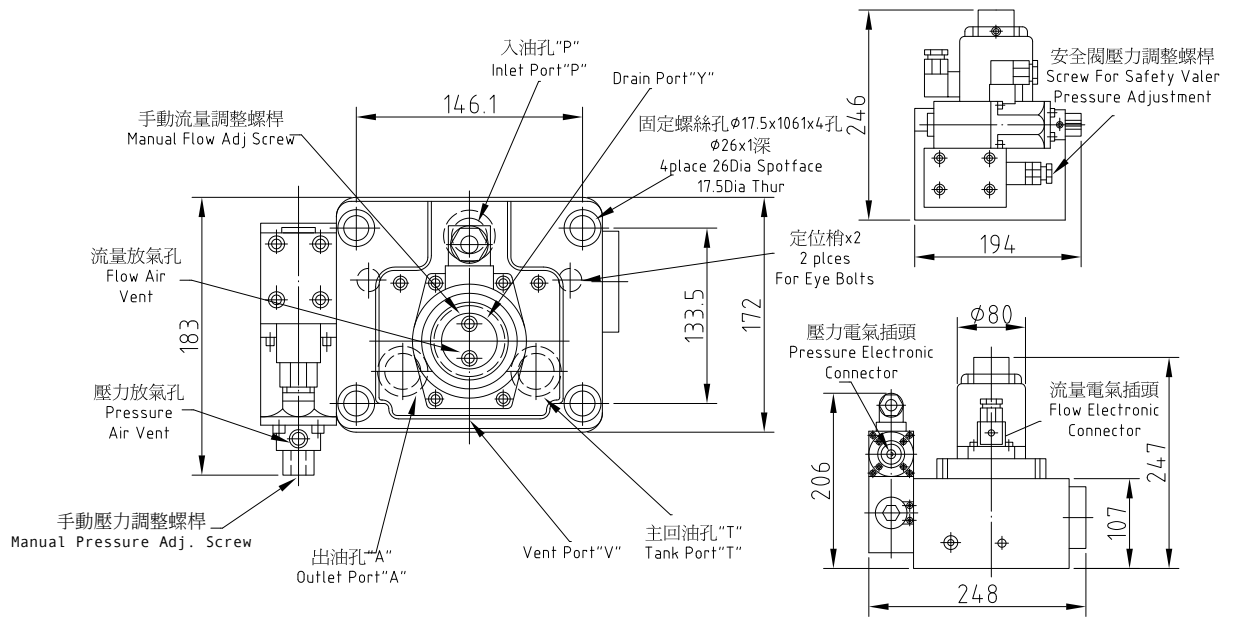



Proportional Valves
Proportional Electro-Hydraulic Relief &
Flow Control Valves

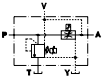

Proportional Valves
Proportional Electro-Hydraulic Relief &
Flow Control Valves





Hydraulic Automation System Designing & Power Unit Assembling

YUTIEN provides customized services to design various machine automation systems to suit the needs of various work environments. In addition, we warmly welcome our customers to choose YUTIEN's own products or to specify the brand components they require. We will always be willing to help customers create the best "Low noise, Power saving, High efficiency" power unit.

For available services, please contact our sales department, head office (Taiwan)



Hydraulic Automation System Designing &
Power Unit Assembling





Hydraulic Automation System Designing & Power Unit Assembling



A series of horizontal dotted lines providing a template for handwritten notes or calculations.





油田油壓股份有限公司
YUTiEN HYDRAULIC INDUSTRY CO., LTD.

414021 台中市烏日區大明北路 129 巷 2 號
No.2 Lane 129 TaimInchg N. Rd. Wuri Dist.
Taichung City 414021, Taiwan

TEL : +886-4-23356915
FAX : +886-4-23356925
E-mail : service@yutien.com

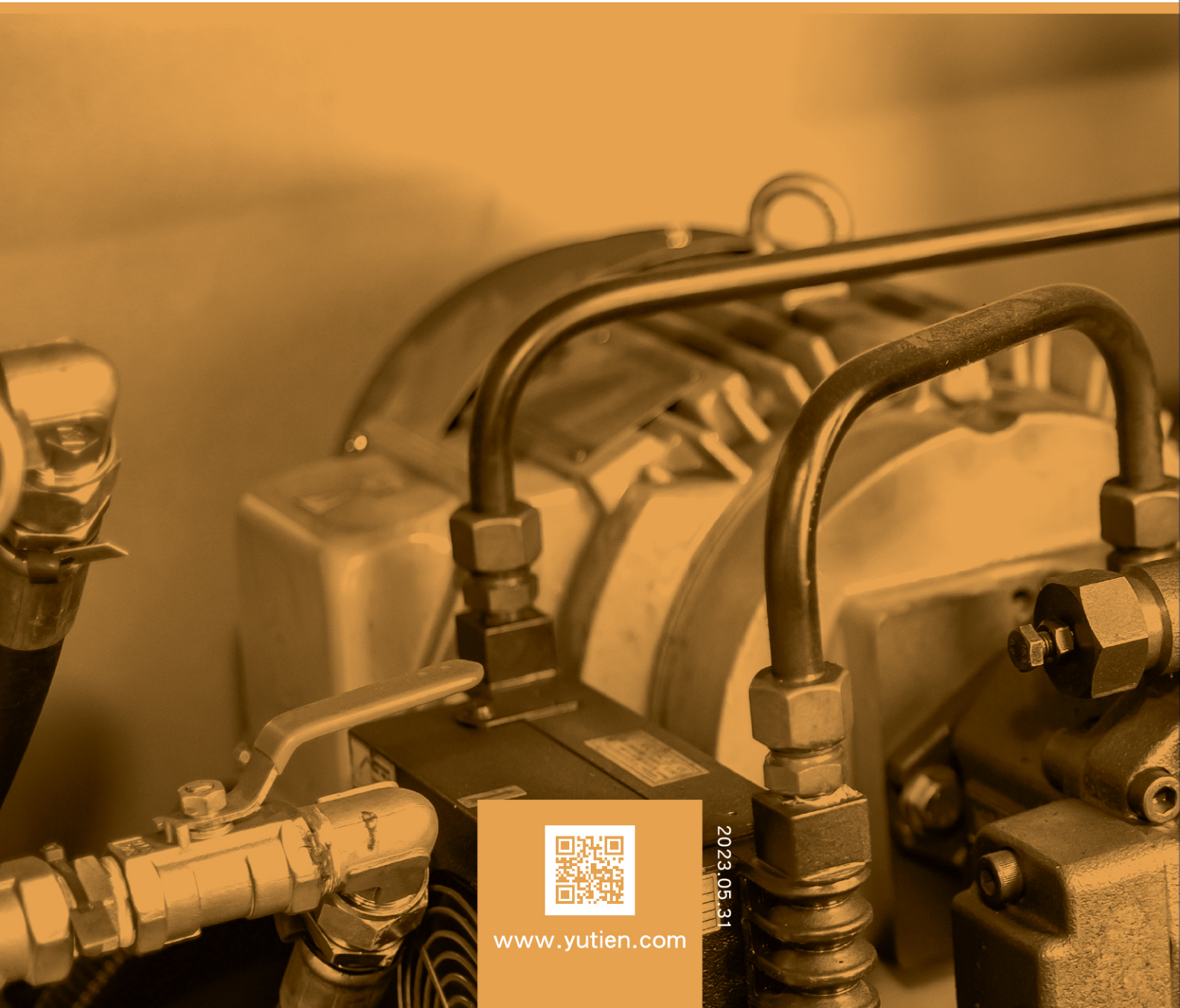

www.yutien.com

2023.05.31